

本站大部分资源收集于网络，只做学习和交流使用，版权归原作者所有。若您需要使用非免费的软件或服务，请购买正版授权并合法使用。本站发布的内容若侵犯到您的权益，请联系站长删除，我们将及时处理。下图为站长及技术的微信二维码



8.1 定影单元	32
8.2 出口传感器 (S3)	33
8.3 定影单元上盖板/出口导板	34
8.4 中央加热灯 (LAMP1)	35
8.5 侧加热灯 (LAMP2)	35
8.6 基座单元	36
8.7 压力辊	36
8.8 分离爪	37
8.9 热辊/热辊轴套	37
8.10 中央热保险 (THMO1) /侧热保险 (THMO2)	38
8.11 中央热敏电阻 (THMS1) /侧热敏电阻 (THMS2) /边缘热敏电阻 (THMS3)	39
8.12 出口辊	39
<b>九、自动双面单元 (ADU)</b>	<b>41</b>
9.1 自动双面单元 (ADU)	41
9.2 ADU 传感器 (S8)	41
9.3 定影导板单元	41
9.4 出口电机 (M6)	42
9.5 ADU 离合器 (CLT4)	42
9.6 ADU 风扇风道单元	42
9.7 ADU 下输纸辊	43
9.8 ADU 上输纸辊	43
9.9 ADU 输纸辊	44
<b>十、选购件安装和更换</b>	<b>44</b>
10.1 自动双面输稿器 (RADF)	44
10.2 纸盒单元 (PFU)	45
<b>十一、电路板相关</b>	<b>46</b>
11.1 主板	46
11.2 低压电源板 (LVPS)	46
11.3 高压板 (HVPS)	47

## 拆装注意事项：

- 1、拆装应由有资质的技术服务人员完成
- 2、拆装前，务必关机并拔掉设备的电源线
- 3、抬起设备时务必由两人握住设备对应的把手
- 4、千万不要通过抬扫描架来抬起机器，否则会造成扫描架变形
- 5、拆装过程中，注意自攻螺丝和普通螺丝的区别，以避免损坏塑料件的螺丝孔

## 一、盖板

### 1.1 左盖板

1、拧下两颗螺丝，取下左盖板[1]

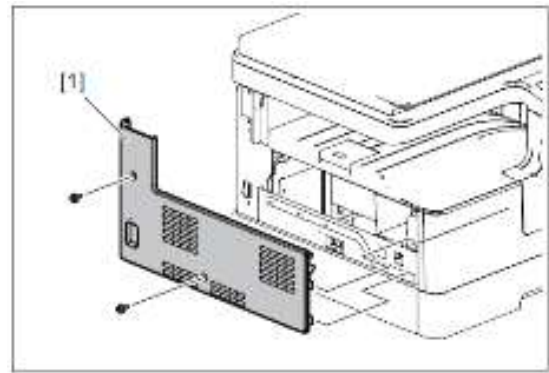

### 1.2 内部托盘

1、拆下左盖板  
参考“1.1 左盖板”

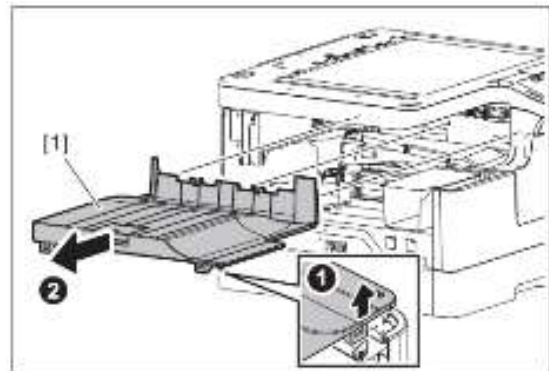

2、取下内部托盘[1]

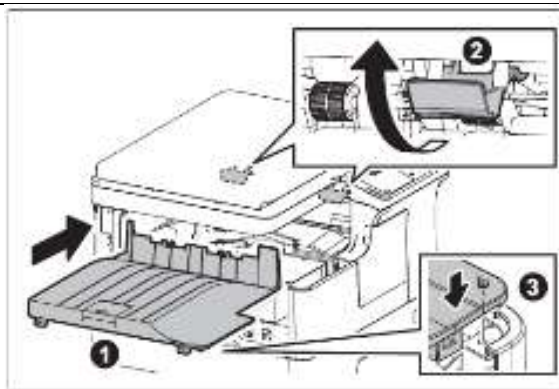

**注意：**安装内部托盘时，注意先将出口处两处防折角拨杆抬起

### 1.3 右前盖板

1、拆下第一纸盒

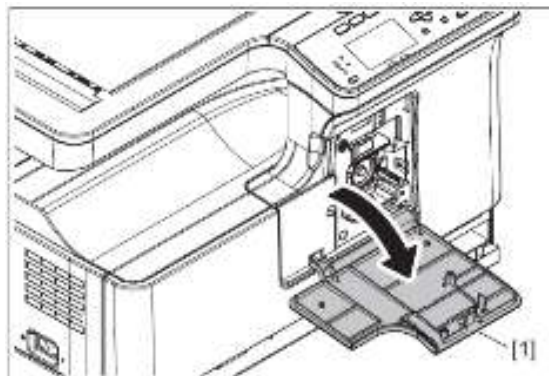

2、打开墨粉盒盖板[1]

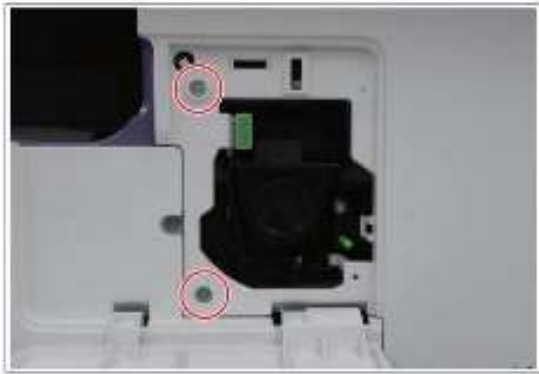

3、拧下两颗螺丝

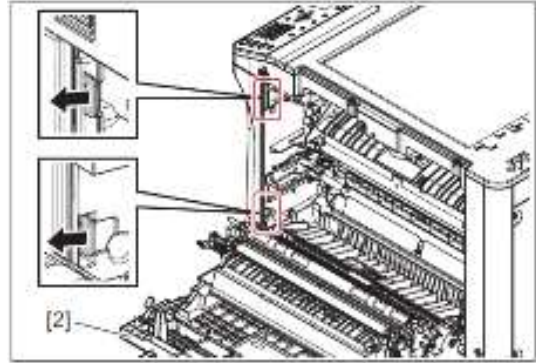

4、打开侧盖板[2]

5、释放三处卡扣，取下右前盖板[3]

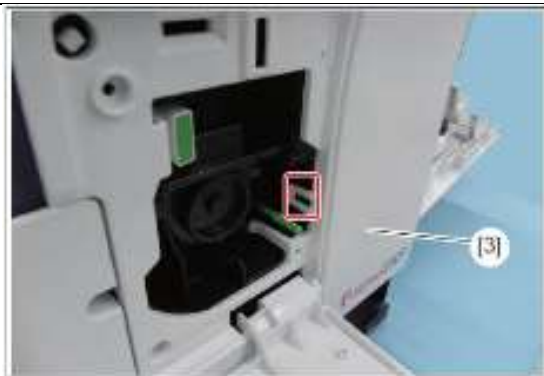

## 1.4 左前盖板

- 1、拆下右前盖板  
参考“1.3 右前盖板”
- 2、拆下内部托盘  
参考“1.2 内部托盘”

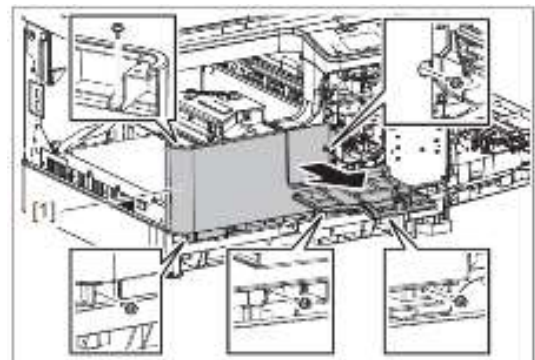

3、拧下五颗螺丝，取下左前盖板[1]

## 1.5 墨粉盒盖板

- 1、拆下右前盖板  
参考“1.3 右前盖板”
- 2、拆下左前盖板  
参考“1.4 左前盖板”

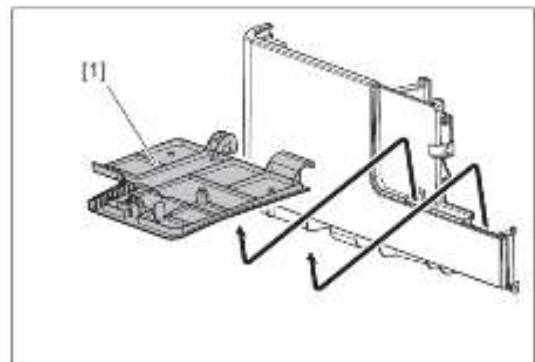

3、取下墨粉盒盖板[1]

## 1.6 托盘前盖板

- 1、拆下内部托盘  
参考“1.2 内部托盘”
- 2、拆下右前盖板  
参考“1.3 右前盖板”

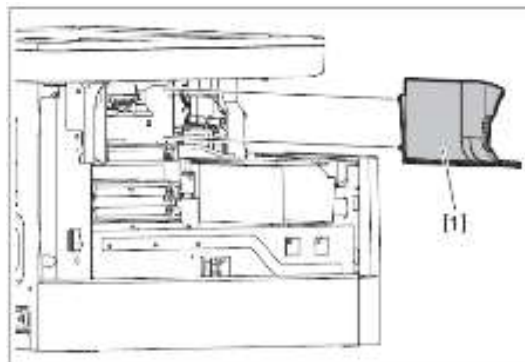

- 3、取下托盘前盖板[1]

## 1.7 托盘后盖板

- 1、拆下内部托盘  
参考“1.2 内部托盘”

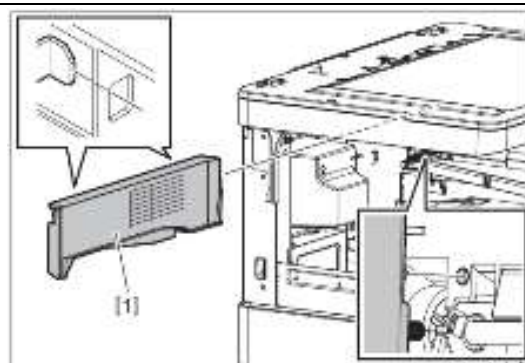

- 2、取下托盘后盖板[1]

注意：安装托盘后盖板时，注意将销子插入支架对应销孔中

## 1.8 后盖板

- 1、拧下三颗螺丝，取下后盖板[1]

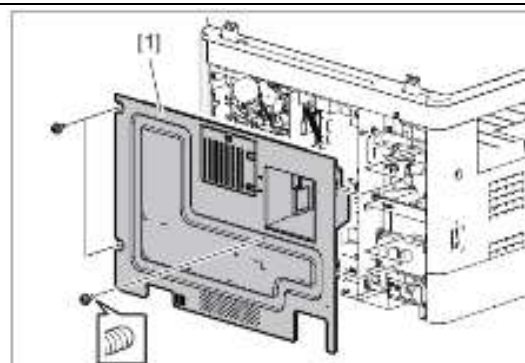

注意：安装后盖板时，注意将右侧销子插入对应销孔中

## 1.9 右后盖板

- 1、打开侧盖板

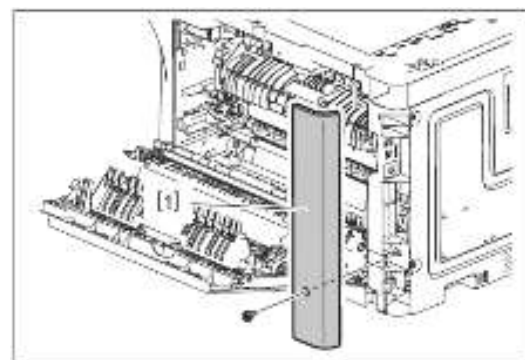

- 2、拧下一颗螺丝，取下右侧后盖板[1]



## 1.10 右下盖板

1、拆下第一纸盒

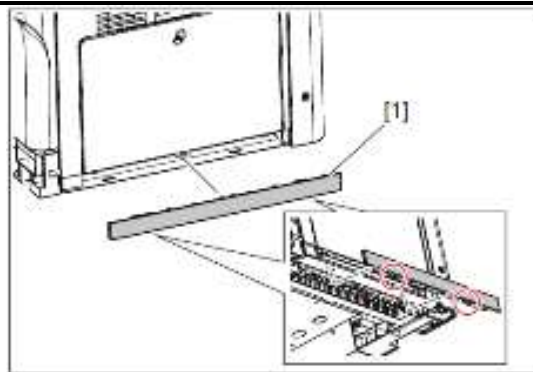

2、释放两处卡扣，取下右下盖板[1]

## 1.11 侧盖板

1、拆下右下盖板

参考“1.10 右下盖板”

2、拆下后盖板

参考“1.8 后盖板”

3、拆下右后盖板

参考“1.9 右后盖板”

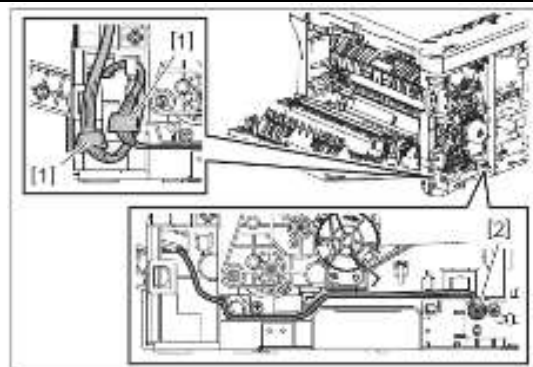

4、断开两处线束[1],拧下一颗螺丝[2],断开接地线

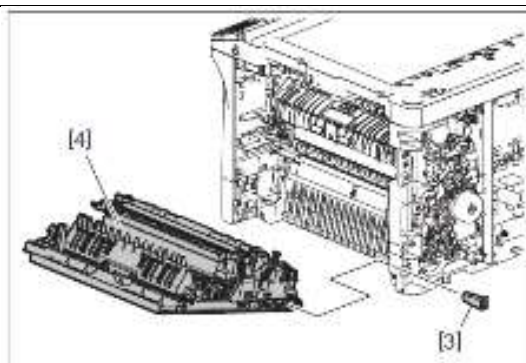

5、取出固定销子[3],取下侧盖板[4]

## 1.12 上盖板（含稿台玻璃）

1、拆下稿台盖板或者输稿器

2、打开侧盖板

3、拆下控制面板单元

参考“2.1 控制面板单元”

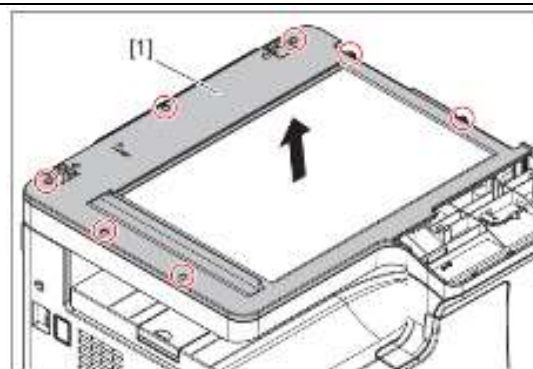

4、拧下七颗螺丝，取下上盖板[1]

注意：稿台玻璃背面添加了润滑油，拆装时注意不要误触

## 二、控制面板

### 2.1 控制面板单元

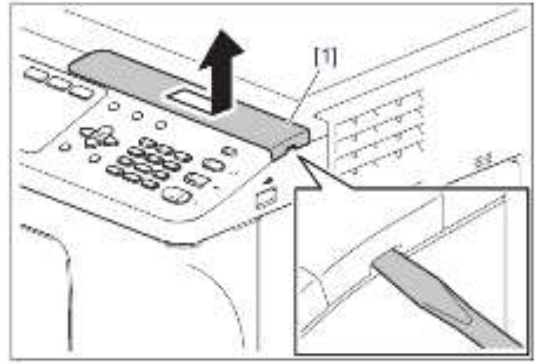

1、使用一字螺丝刀插入盖板[1]右侧槽孔，取下盖板[1]

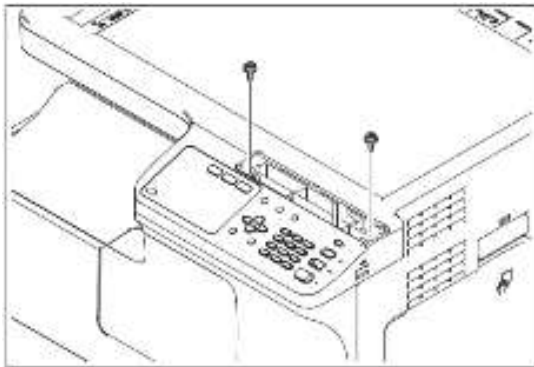

2、拧下两颗螺丝

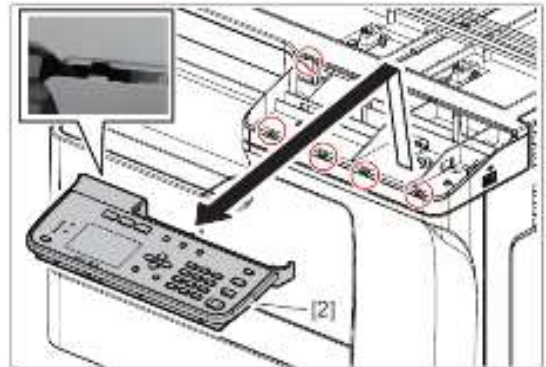

3、释放五处卡扣，拆下控制面板单元[2]

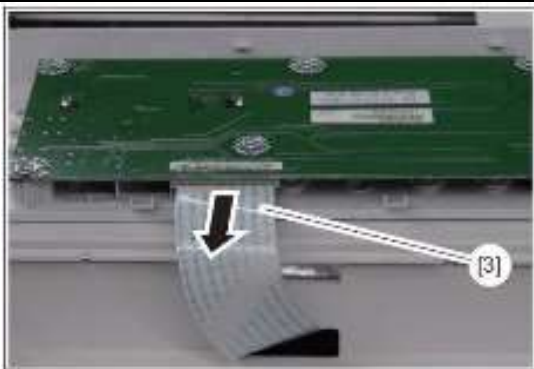

4、断开控制面板一侧的一处线束[3]

### 2.2 控制面板电路板 (HPNL)

1、拆下控制面板单元

参考“2.1 控制面板单元”

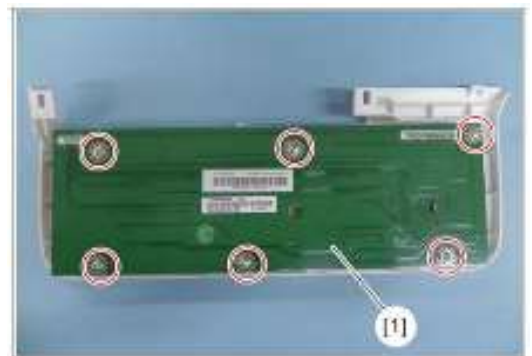

2、拧下六颗螺丝，拆下控制面板电路板[1]

## 2.3 LED 面板

- 1、拆下控制面板电路板  
参考“2.2 控制面板电路板”

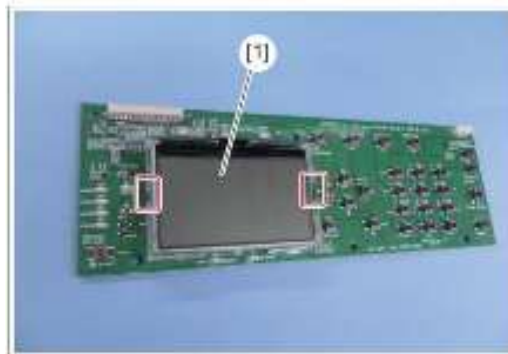

- 2、释放两处卡扣，拆下 LED 面板盖板[1]



- 3、断开两处线束，释放两处卡扣，取下 LED 面板[2]

## 2.4 USB 线

- 1、拆下控制面板单元  
参考“2.1 控制面板单元”
- 2、拆下上盖板  
参考“1.12 上盖板”
- 3、拆下后盖板  
参考“1.8 后盖板”

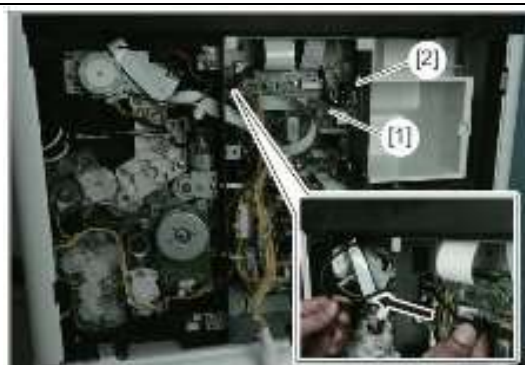

- 4、断开 USB 线[2]与主板[1]的连接

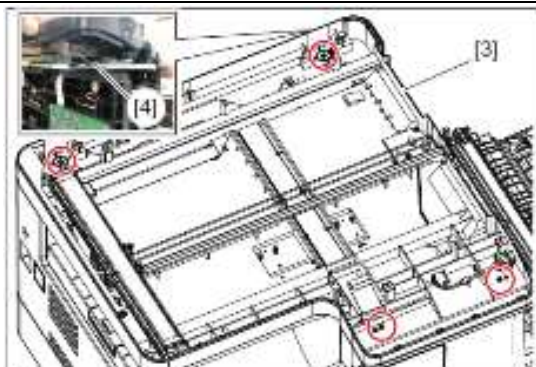

- 5、拧下四颗螺丝，将扫描单元[3]一侧适当抬起，将 USB 线[4]一侧抽出

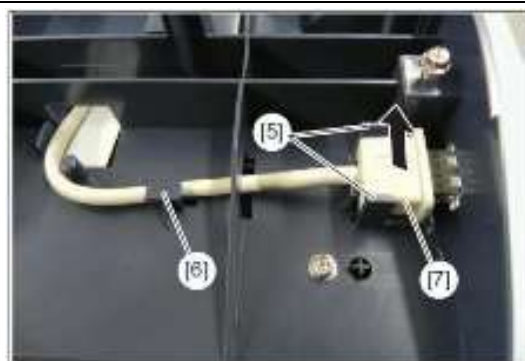

- 6、释放卡扣[5],将 USB 线[7]从限位卡扣[6]中取出



## 三、扫描单元

### 3.1 CIS 单元

- 1、拆下上盖板（含稿台玻璃）  
参考“1.12 上盖板”

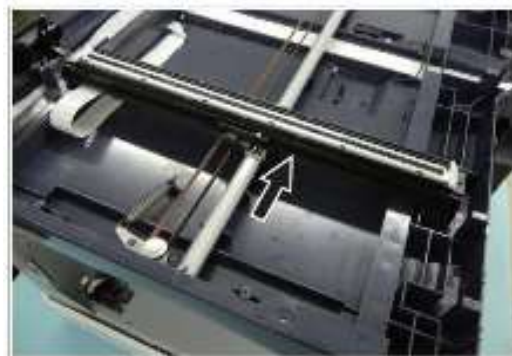

- 2、将 CIS 移动至扫描腔中间位置

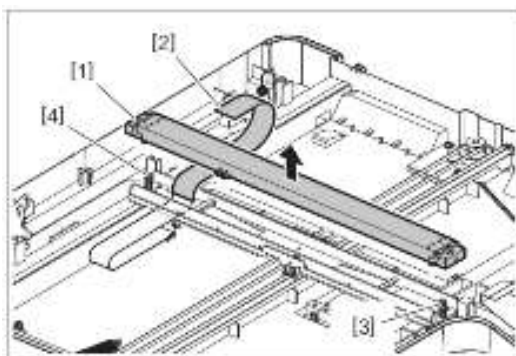

- 3、提起 CIS 单元[1]，从 CIS 单元背面断开一处线束[2]，拆下 CIS 单元

注意：

- a、不要用手指直接接触 CIS 表面
- b、不要将 CIS 正面朝下放置
- c、更换 CIS 单元后执行 05-3219
- d、如果弹簧脱落，则将黑色弹簧[3]连接到前侧，棕色弹簧[4]连接到后侧。

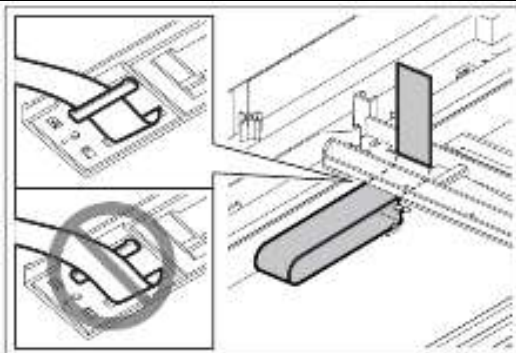

注意：安装 CIS 单元时，注意走线并将扁平线束置于对应线束槽内

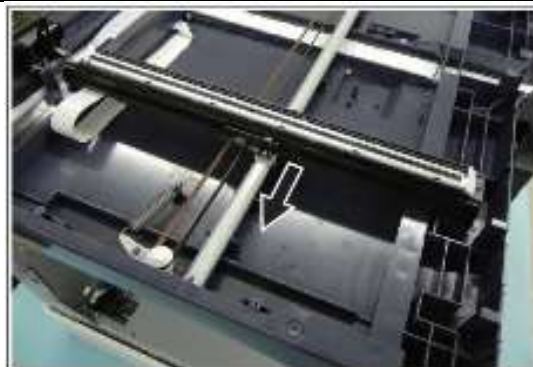

注意：安装 CIS 单元后，将其移动至扫描腔左侧

### 3.2 CIS 托架

- 1、拆下 CIS 单元  
参考“3.1 CIS 单元”

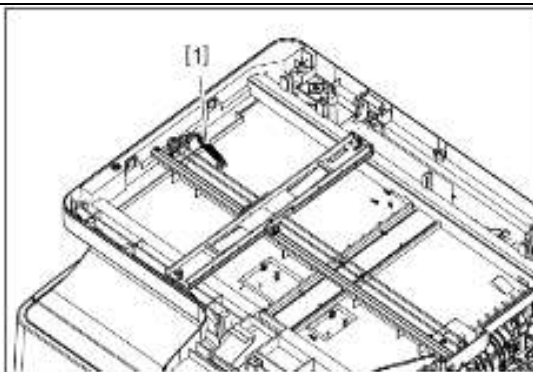

- 2、取下张紧弹簧[1]

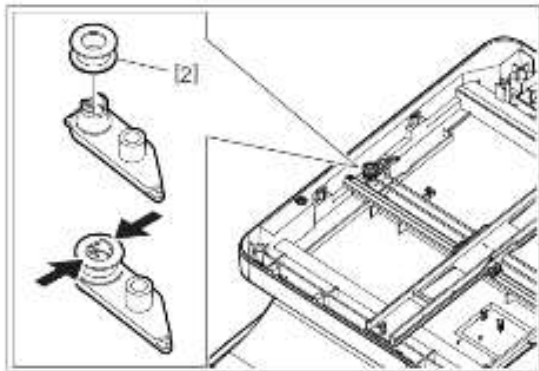

3、取下滑轮[2]

注意：更换滑轮时，需要在接触位置添加润滑油

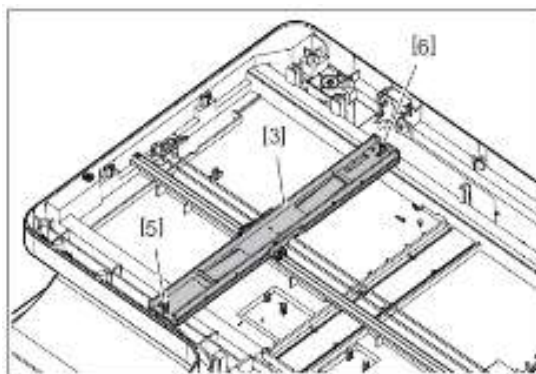

4、拆下 CIS 托架[3]

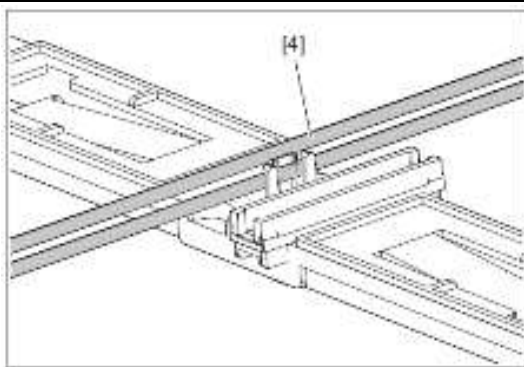

5、拧下 CIS 单元驱动皮带[4]

### 3.3 扫描电机 (M1)

1、拆下后盖板

参考“1.8 后盖板”



2、断开主板上的一处线束[1] (CN6)

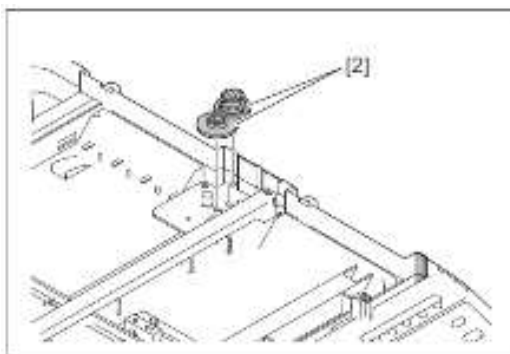

3、拆下 CIS 托架。参考“3.2 CIS 托架”

4、取下齿轮[2]

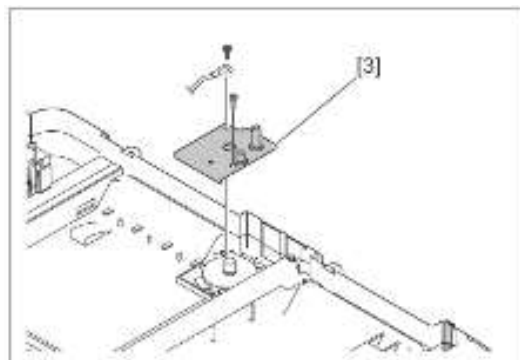

5、拧下两颗螺丝，拆下电机支架[3]

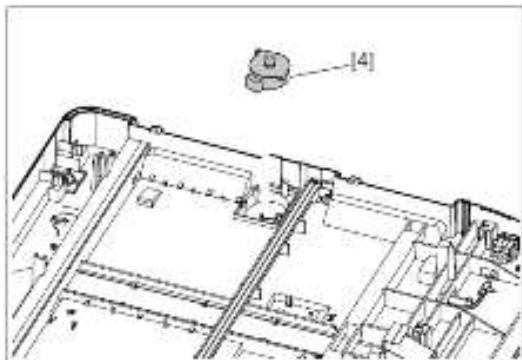

6、从导轨中释放线束后，拆下扫描电机[4]



注意：安装扫描电机时，注意固定接地线



注意：安装扫描电机时，注意将线束置于对应线束槽中



### 3.4 稿台盖板传感器 (S7)

1、拆下上盖板（含稿台玻璃）  
参考“1.12 上盖板”



2、拆下传感器臂杆[1]，并断开一处线束[2]

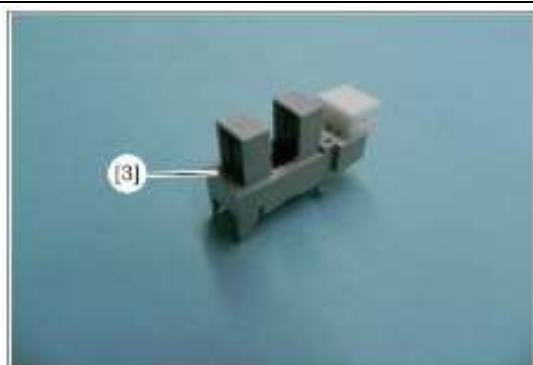

3、松开两处卡扣，拆下稿台盖板传感器[3]



## 3.5 自动原稿检测传感器 (S9)

1、拆下上盖板 (含稿台玻璃)

参考 “1.12 上盖板”

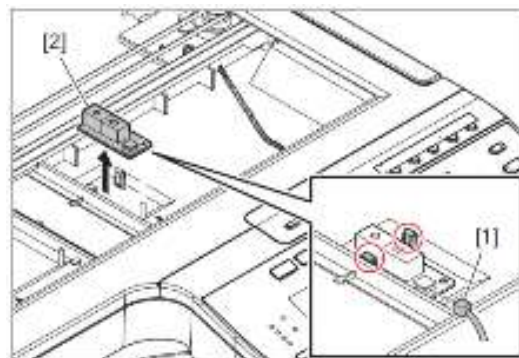

2、断开一处线束[1]，释放两处卡扣，取下自动原稿检测传感器 (S9) [2]

## 四、激光单元

### 4.1 激光单元

1、拆下内部托盘

参考 “1.2 内部托盘”

2、拆下 ADU 风扇风道

参考 “9.6 ADU 风扇风道”

注意：未安装 ADU 的机型无风扇风道

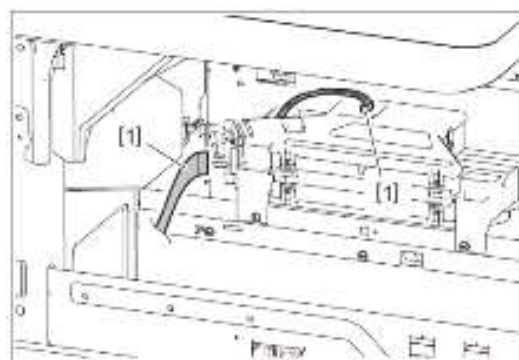

2、断开激光单元的两处线束[1]

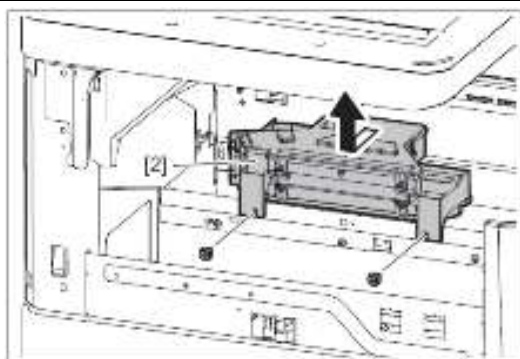

3、拧下两颗螺丝，抬起激光单元[2]并取下

注意：

- 1、不要用手指触碰激光单元的 LDRS 板
- 2、放置激光单元时，注意不要使多棱镜电机受压
- 3、不要场地上进行激光单元本体的拆装
- 4、务必保持狭缝玻璃的清洁

## 五、驱动系统

### 5.1 主电机

1、拆下后盖板

参考 “1.8 后盖板”



2、断开一处线束[1]，拧下两颗螺丝，拆下主电机[2]

## 5.2 加粉电机 ( M2 )

- 1、拆下后盖板  
参考 “1.8 后盖板”



- 2、拧下一颗螺丝，断开一处线束[1]

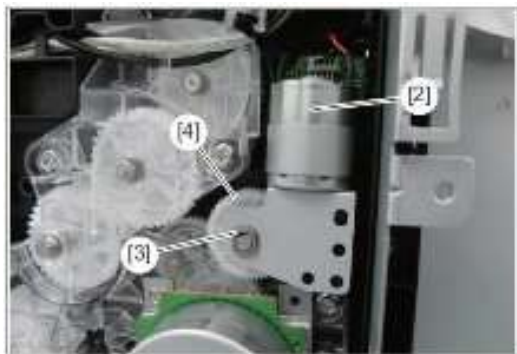

- 3、连同支架一起将加粉电机[2]取下，去除轴套[3]和齿轮[4]

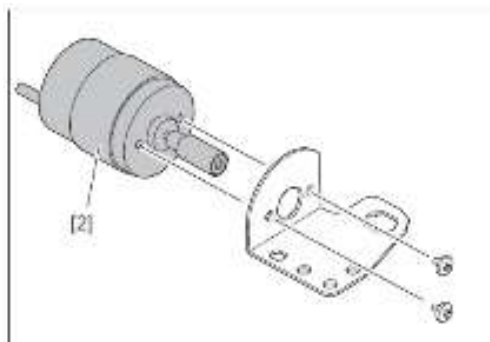

- 4、拧下两颗螺丝，拆下加粉电机[2]  
注意：安装时注意螺丝长度，否则可能损坏电机

## 5.3 出口驱动单元

- 1、拆下后盖板  
参考 “1.8 后盖板”



- 2、拧下两颗螺丝 ( M3X10 )，拆下出口驱动单元[1]  
注意：安装时注意螺丝长度，否则可能损坏螺丝孔

## 5.4 上驱动单元

- 1、拆下后盖板  
参考 “1.8 后盖板”
- 2、拆下出口驱动单元  
参考 “5.3” 出口驱动单元



- 3、拧下三颗螺丝 ( M3X10 )，拆下上驱动单元[1]  
注意：安装时注意螺丝长度，否则可能损坏螺丝孔



## 5.5 下驱动单元

1、拆下处理单元

参考“7.1 处理单元”

2、拆下后盖板

参考“1.8 后盖板”

3、拆下纸盒进纸离合器

参考“6.10 纸盒进纸离合器 (CLT2)”

4、拆下定位离合器

参考“6.11 定位离合器(CLT1)”

5、拆下主电机

参考“5.1 主电机”

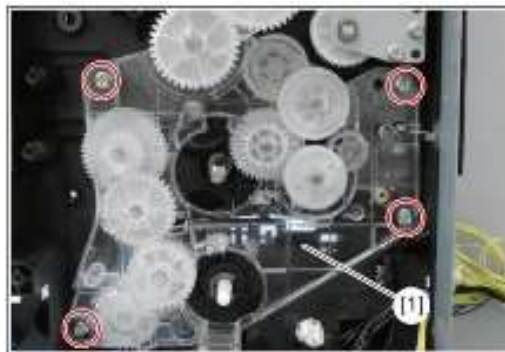

6、拧下四颗螺丝 ( M3X10 ), 拆下下驱动单元[1]

注意：安装时注意螺丝长度，否则可能损坏螺丝孔

## 六、纸路

### 6.1 旁路单元

1、拆下侧盖板

参考“1.11 侧盖板”

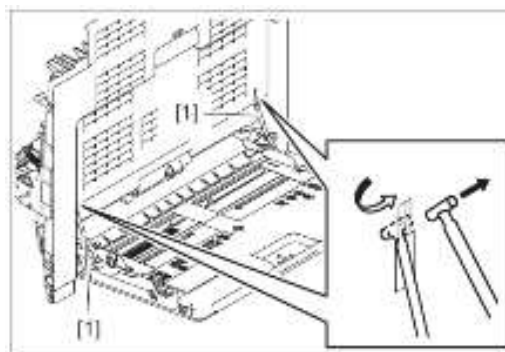

2、打开旁路，将两侧连接带[1]旋转 90°并拆下

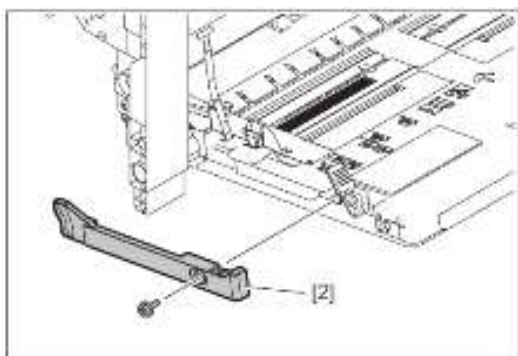

3、拧下一颗螺丝，拆下连接臂杆[2]

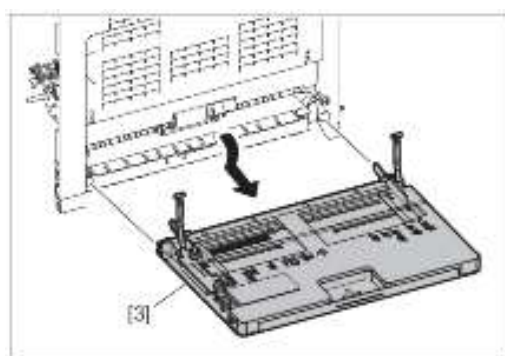

4、向下倾斜拉出旁路单元[3]

### 6.2 旁路进纸离合器 (CLT3)

1、拆下侧盖板

参考“1.11 侧盖板”

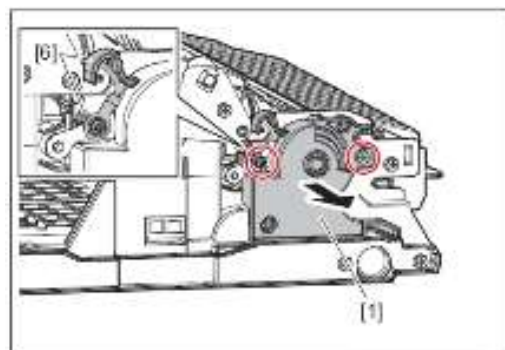

2、拧下两颗螺丝，拆下盖板[1]

注意：安装时注意接地线走线

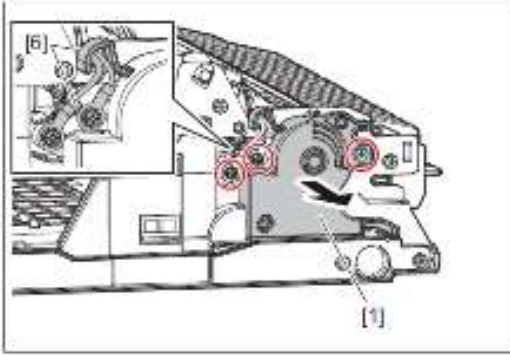

如果安装了 ADU，则需要拧下三颗螺丝再拆下盖板[1]  
注意：安装时注意接地线走线

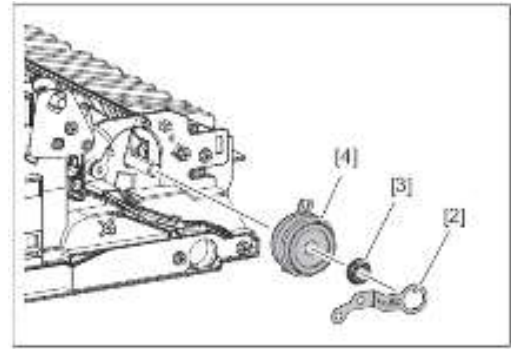

3、拆下簧片[2]和轴套[3],拆下旁路进纸离合器[4]



4、断开一处线束[5]



注意：安装离合器时，注意离合器限位卡口[7]位置

### 6.3 转分座

1、打开侧盖板

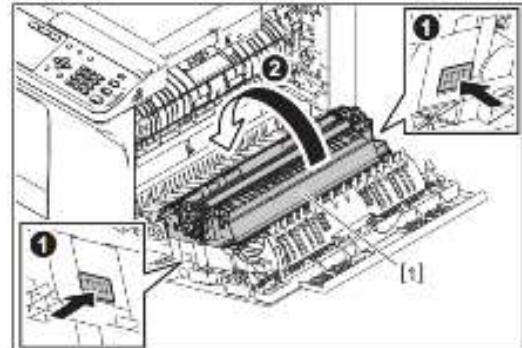

2、释放两侧卡扣，拆下转分座

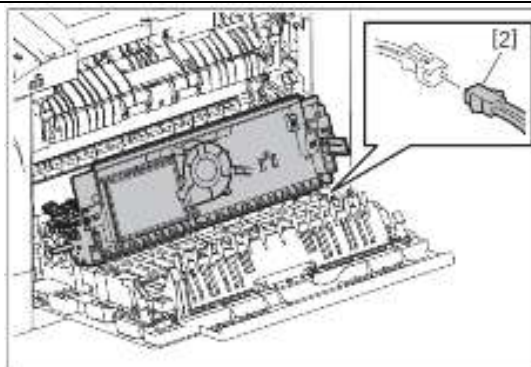

3、断开一处线束[2]

## 6.4 下旁路进纸导板

- 1、拆下侧盖板  
参考“1.11 侧盖板”
- 2、拆下旁路进纸离合器  
参考“6.2 旁路进纸离合器”

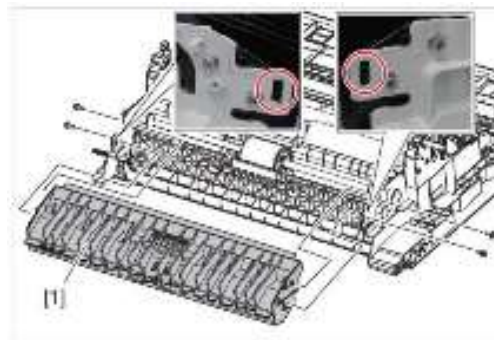

- 3、拧下四颗螺丝，释放两侧卡扣，拆下下旁路进纸导板[1]

## 6.5 旁路搓纸辊

- 1、拆下侧盖板  
参考“1.11 侧盖板”
- 2、拆下旁路进纸离合器  
参考“6.2 旁路进纸离合器”
- 3、拆下下旁路进纸导板  
参考“6.4 下旁路进纸导板”



- 4、释放两处卡扣[1]，将辊轴向后侧滑动并取下



- 5、取下轴套[3]，拆下旁路搓纸辊[4]

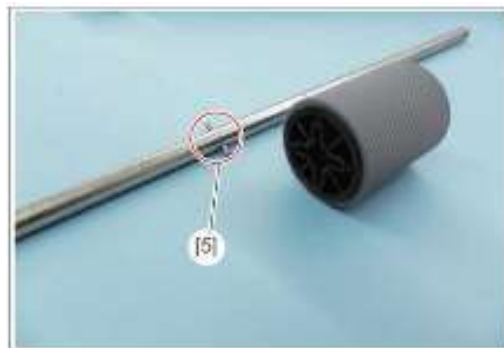

注意：安装搓纸辊时，注意安装定位销[5]

## 6.6 旁路分离垫

- 1、拆下侧盖板  
参考“1.11 侧盖板”
- 2、拆下下旁路进纸导板  
参考“6.4 下旁路进纸导板”

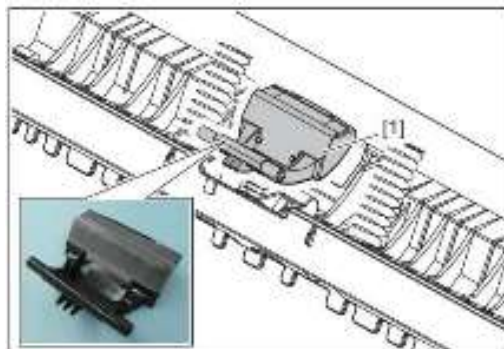

- 3、拆下旁路分离垫[1]

## 6.7 旁路进纸传感器 (S6)

- 1、拆下旁路搓纸辊  
参考“6.5 旁路搓纸辊”

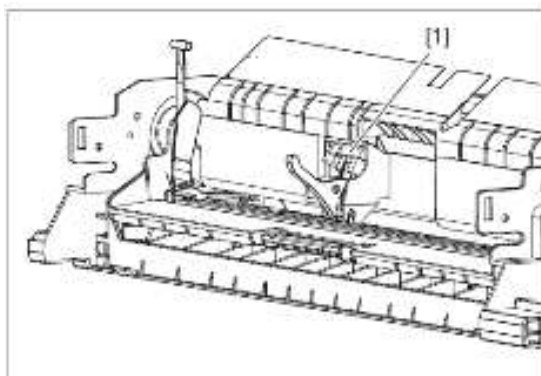

- 2、释放三处卡扣，取下旁路进纸传感器[1]，并断开线束

## 6.8 纸盒搓纸辊

- 1、拆下纸盒

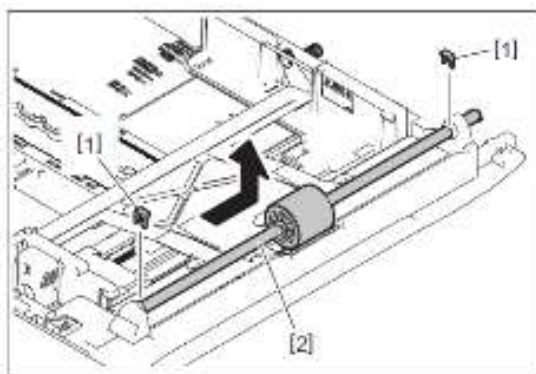

- 2、拆下前后侧卡扣[1]，将辊轴[2]向后侧移动并取下

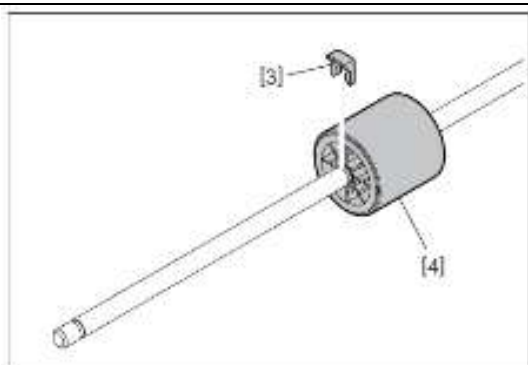

- 3、取下卡扣[3]，拆下纸盒搓纸辊[4]

## 6.9 纸盒分离垫

- 1、拆下纸盒搓纸辊  
参考“6.8 纸盒搓纸辊”

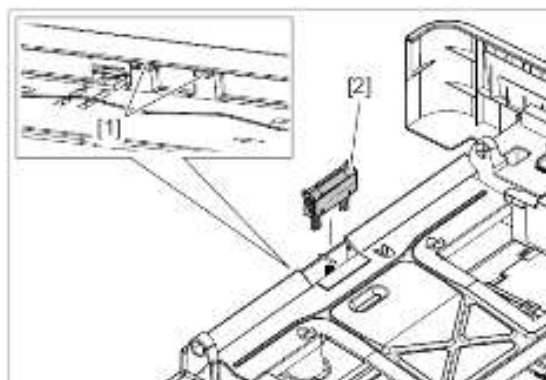

- 2、释放纸盒底部的两处卡扣[1]，取下纸盒分离垫[2]



## 6.10 纸盒进纸离合器 ( CLT2 )

1、拆下后盖板  
参考“1.8 后盖板”



2、断开一处线束[1]



3、拧下一颗螺丝，释放卡扣，拆下离合器盖板[2]



4、拆下纸盒进纸离合器[3]

注意：安装离合器时，注意离合器限位位置正确

## 6.11 定位离合器 ( CLT1 )

1、拆下后盖板  
参考“1.8 后盖板”



2、断开一处线束[1]

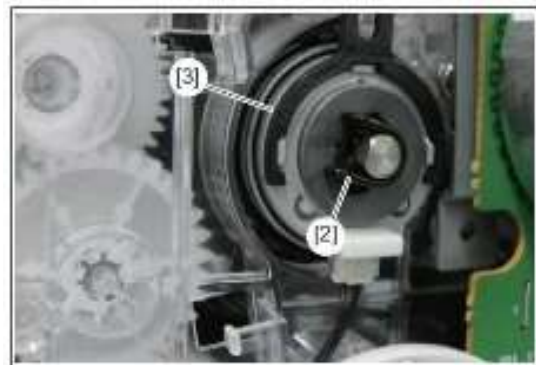

3、取下卡扣[2]，拆下定位离合器[3]

注意：安装离合器时，注意离合器限位位置正确



## 6.12 定位辊（金属辊）

- 1、打开侧盖板
  - 2、拆下处理单元
- 参考“7.1 处理单元”
- 3、拆下定位离合器
- 参考“6.11 定位离合器”

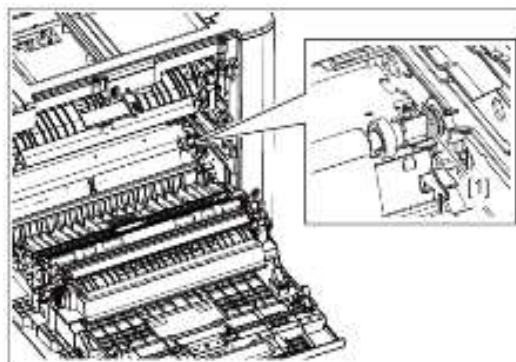

- 4、释放卡扣[1]

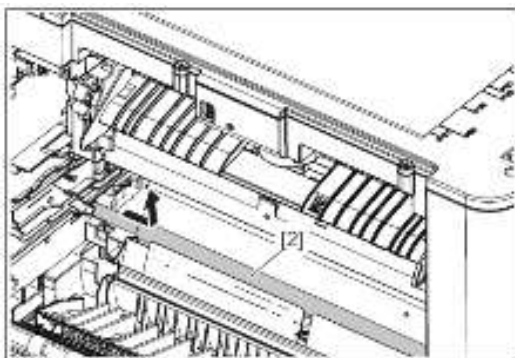

- 5、将定位辊[2]向后侧滑动并取下
- 注意：防止前后侧固定定位辊的轴套掉落

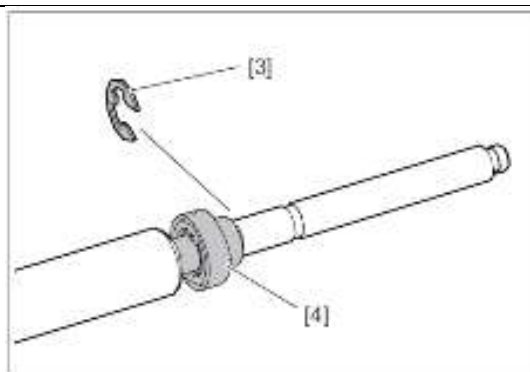

- 6、拆下 E 型环[3]和齿轮[4]

## 6.13 定位辊（橡胶）

- 1、打开侧盖板
  - 2、拆下转分座
- 参考“6.3 转分座”

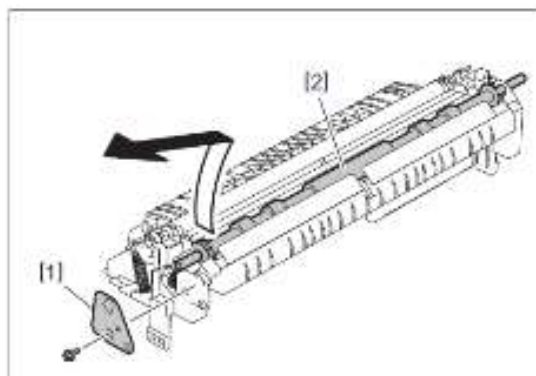

- 3、拧下一颗螺丝，拆下金属支架[1]，向后侧移动定位辊[2]并拆下

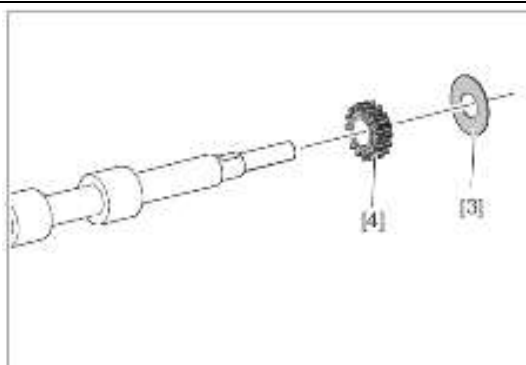

- 4、拆下两个垫片[3]和一个齿轮[4]

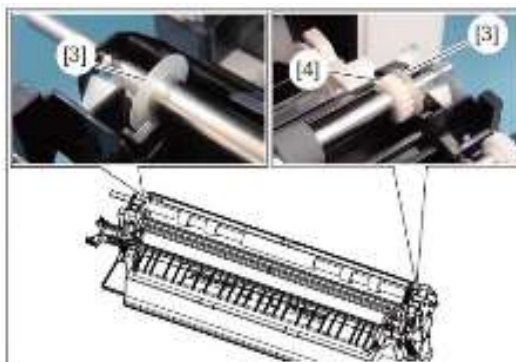

- 注意：安装两处垫片[3]时，注意卡槽位置正确

## 6.14 定位传感器 (S2)

- 1、打开侧盖板
  - 2、拆下转分座
- 参考“6.3 转分座”
- 3、拆下定位辊 (金属)
- 参考“6.12 定位辊 (金属)”

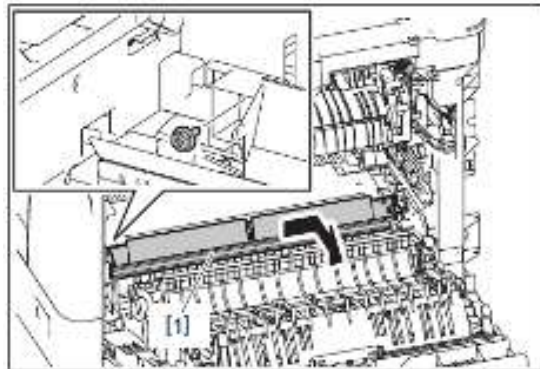

- 4、拧下一颗螺丝，将定位导板[1]向后侧滑动并取下

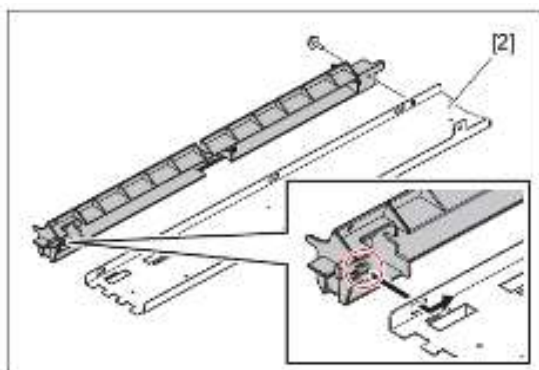

注意：安装定位导板时，注意限位卡扣和销孔到位

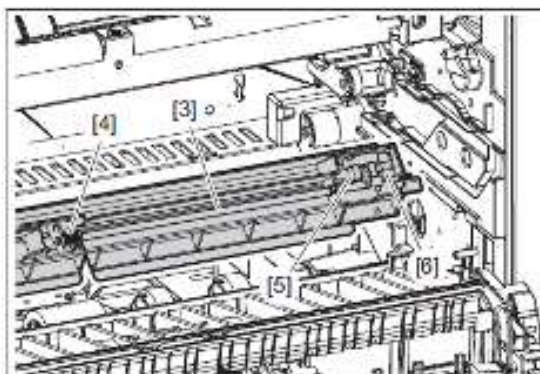

- 5、拆下臂杆[3]、弹簧[4]、释放三处卡扣后拆下定位传感器[5]，并断开线束[6]

## 6.15 纸张空传感器 (S5)

- 1、打开侧盖板
  - 2、拆下纸盒
  - 3、拆下转分座
- 参考“6.3 转分座”
- 4、拆下定位辊 (金属)
- 参考“6.12 定位辊 (金属)”

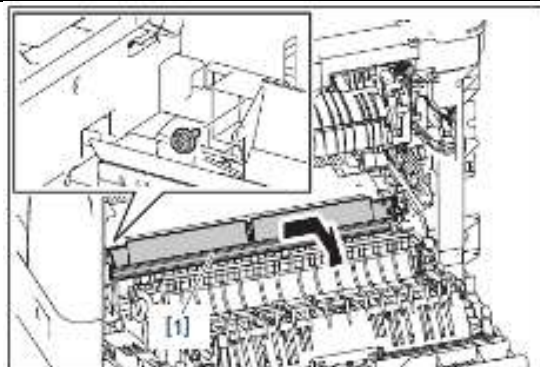

- 5、拧下一颗螺丝，将定位导板[1]向后侧滑动并取下

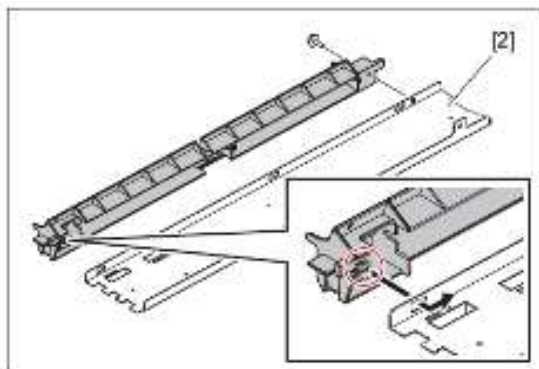

注意：安装定位导板时，注意限位卡扣和销孔到位

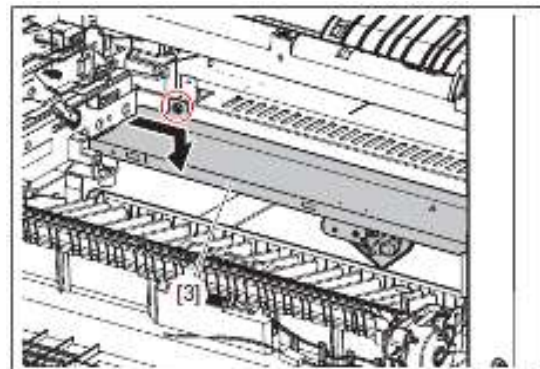

- 6、拧下一颗螺丝，向后侧滑动托盘[3]并拆下

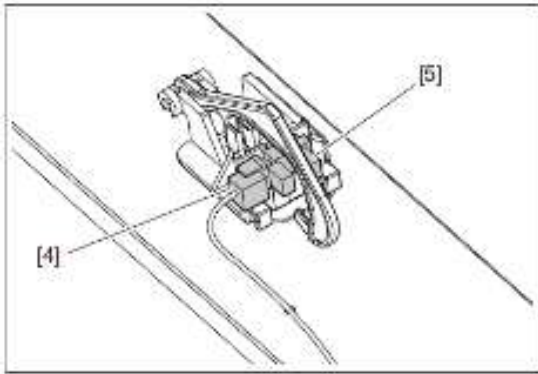

7、将拆下的托盘翻转，断开一处线束[4]，释放三处卡扣，拆下纸张空传感器[5]

## 6.16 纸盒检测开关 ( SW6 )

- 1、拆下后盖板  
参考“1.8 后盖板”
- 2、拆下纸盒

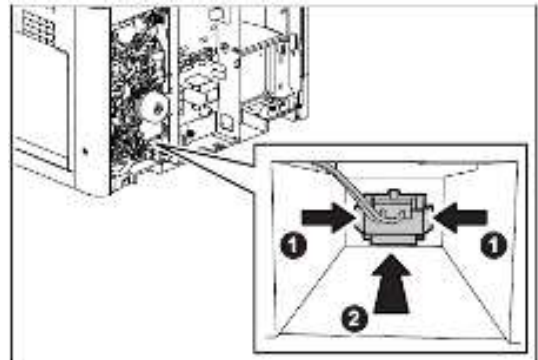

3、释放两侧卡扣

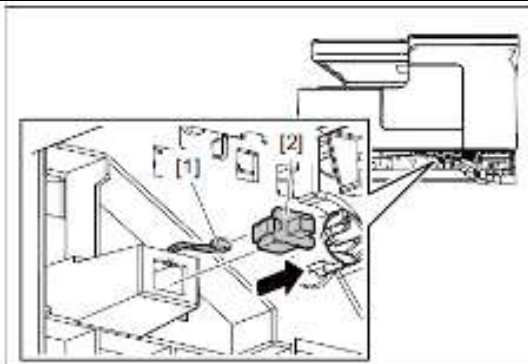

4、拆下纸盒检测开关[2]并断开线束[1]

## 七、处理单元相关

### 7.1 处理单元

- 1、拆下墨粉盒
- 2、打开侧盖板



3、断开一处线束[1]





4、推送连杆[2]以释放锁扣



注意：检查连杆锁定/释放位置

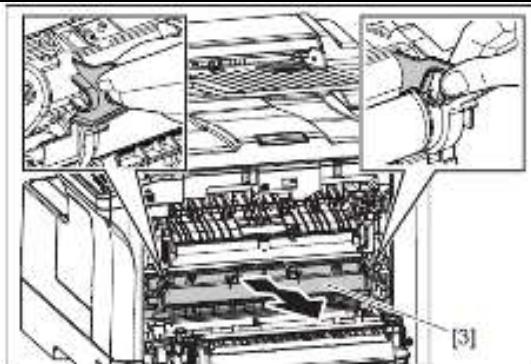

5、握持两侧把手位置，将处理单元抽出[3]

## 7.2 鼓清洁单元

### 1、拆下处理单元

参考“7.1 处理单元”

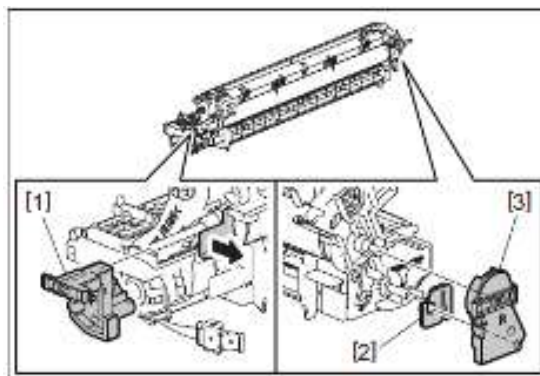

2、拆下前侧[1]/后侧限位块[3]和挡片

注意：拆装时注意避免感光鼓划伤

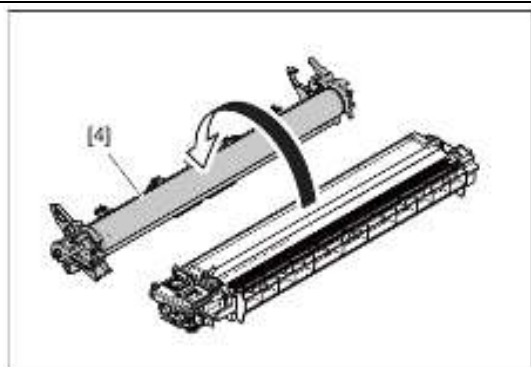

3、取下鼓清洁单元[4]

注意：避免触碰感光鼓的表面并防止感光鼓曝光

## 7.3 感光鼓

- 1、拆下鼓清洁单元  
参考“7.2 鼓清洁单元”

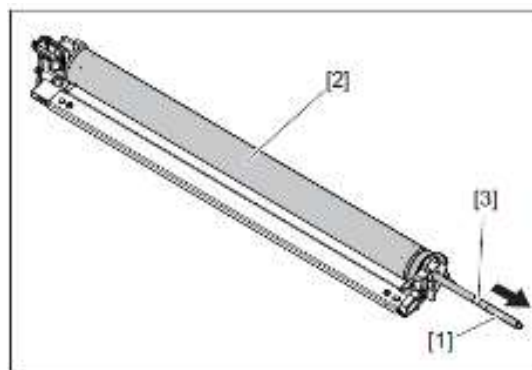

- 2、抽出鼓轴[1]，拆下感光鼓[2]  
注意：避免触碰鼓清洁刮板

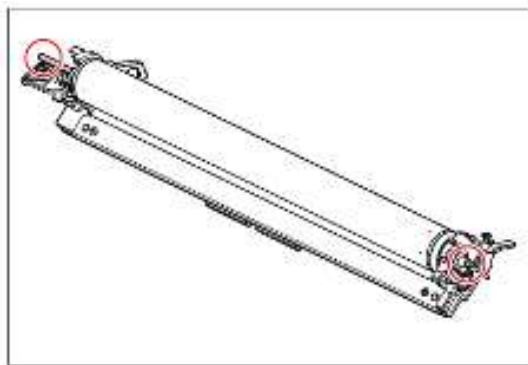

注意：安装鼓轴时，确保安装到位

## 7.4 鼓清洁刮板

- 1、拆下感光鼓  
参考“7.3 感光鼓”

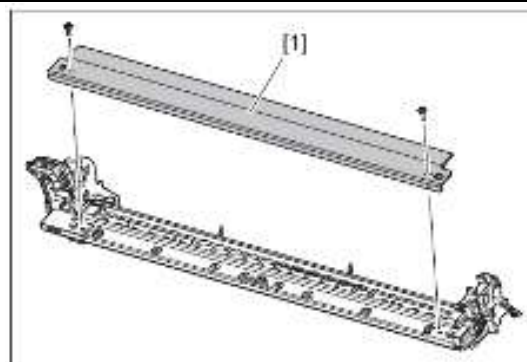

- 2、拧下两颗螺丝，拆下鼓清洁刮板[1]  
注意：尽量避免触碰或刮蹭鼓清洁刮板。

## 7.5 回收刮片

- 1、拆下鼓清洁单元  
参考“7.2 感光鼓”
- 2、拆下感光鼓  
参考“7.3 感光鼓”

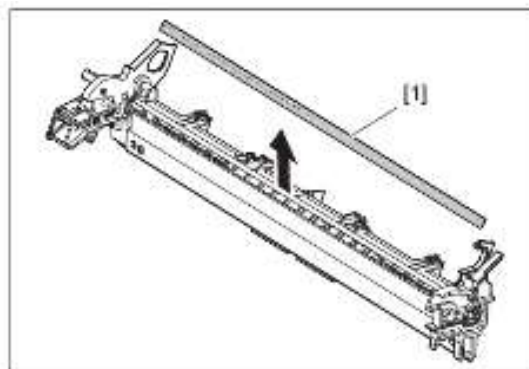

- 3、撕下回收刮片[1]



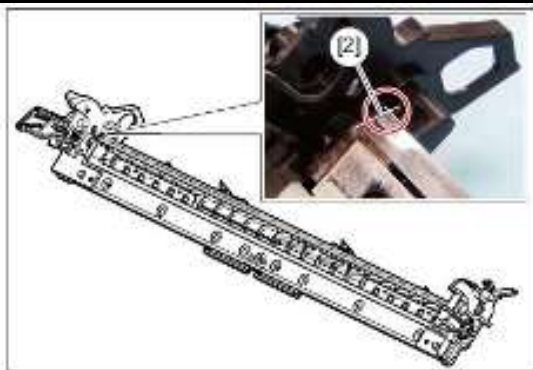

注意：黏贴回收刮片前，需要清洁支架表面，以清洁单元后侧刻度为基准进行黏贴，注意不要触碰到鼓分离爪

## 7.6 鼓分离爪

- 1、拆下感光鼓  
参考“7.3 感光鼓”

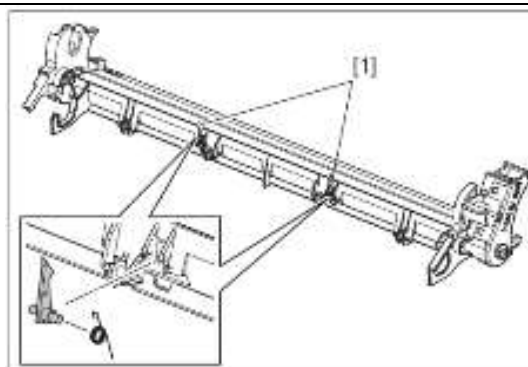

- 2、拆下两个鼓分离爪[1]  
注意：需事先拆下感光鼓以避免划伤，安装后检查结构是否正常

## 7.7 主充单元

- 1、打开侧盖板
- 2、拆下处理单元  
参考“7.1 处理单元”

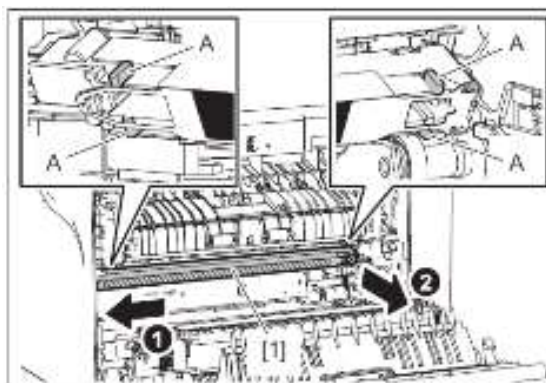

- 3、抓握主充单元 A 位置，并向前侧滑动，之后如图按步骤先将主充后侧向外侧拉，之后再主充单元前侧拉出拆下

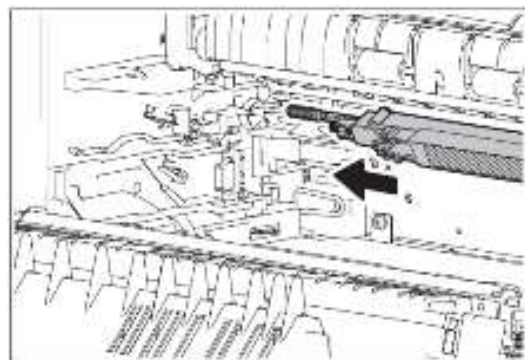

注意：拆装主充单元时，避免触碰定影、栅网。安装时注意先将拉杆前端插入机架对应的孔中

## 7.8 主充栅网

- 1、拆下主充单元  
参考“7.7 主充单元”

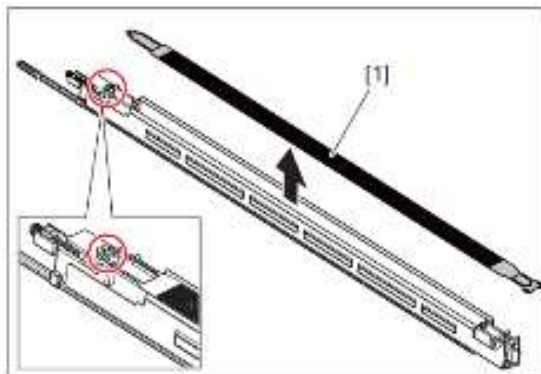

- 2、释放张紧搭扣，拆下主充栅网[1]  
注意：不要触碰到栅网网格部分

## 7.9 主充清洁拉杆

- 1、拆下主充单元  
参考“7.7 主充单元”

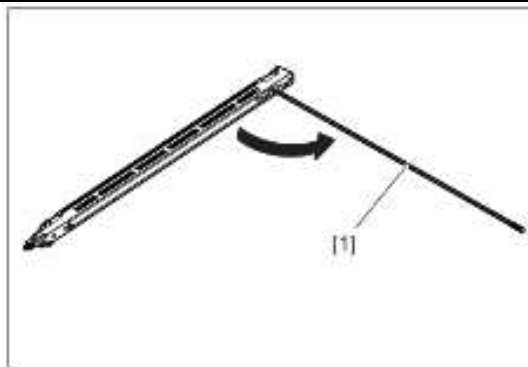

- 2、翻转释放拉杆并旋转 90°，取下主充清洁拉杆[1]

## 7.10 针式电极

- 1、拆下主充单元  
参考“7.7 主充单元”
- 2、拆下主充清洁拉杆  
参考“7.9 主充清洁拉杆”

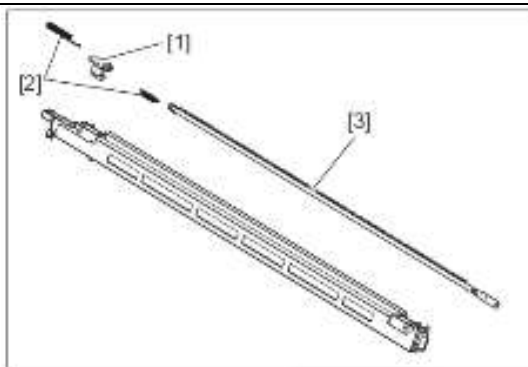

- 3、释放张紧搭扣[1]，拆下两个弹簧[2]，取下针式电极[3]  
注意：避免用手直接接触针式电极锯齿部分，避免弯折针式电极

## 7.11 转印辊

- 1、打开侧盖板

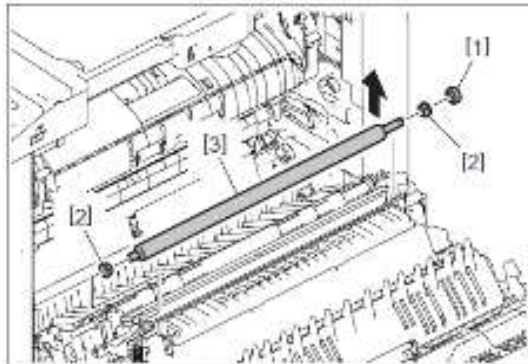

- 2、拆下一个齿轮[1]，两个轴套[2]，取下转印辊[3]

## 7.12 分离电极

- 1、打开侧盖板
  - 2、拆下转分座
- 参考“6.3 转分座”
- 3、拆下定位辊（橡胶）
- 参考“6.13 定位辊（橡胶）”

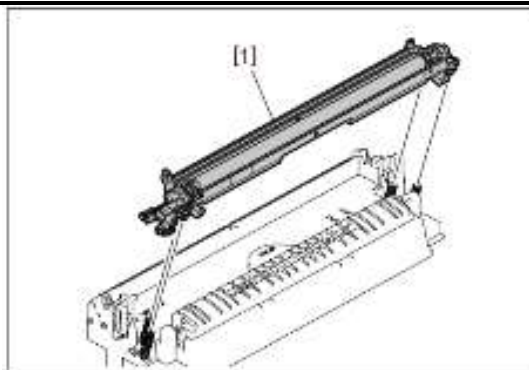

- 4、拆下转印辊单元[1]

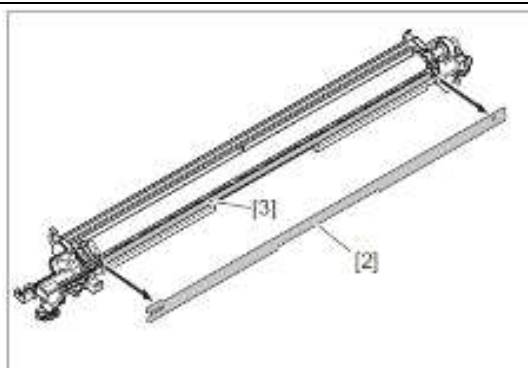

- 5、撕下分离电极保护片[2]后，拆下分离电极[3]

## 7.13 臭氧过滤器

- 1、打开侧盖板
  - 2、拆下转分座
- 参考“6.3 转分座”



- 3、拆下臭氧过滤器[1]

## 7.14 吸气风扇

- 1、打开侧盖板
  - 2、拆下转分座
- 参考“6.3 转分座”



- 3、从线束导轨上释放线束
- 4、释放一处卡扣[1]，拆下吸气风扇[2]

## 7.15 温度/湿度传感器 (S1)

- 1、拆下左盖板  
参考“1.1 左盖板”

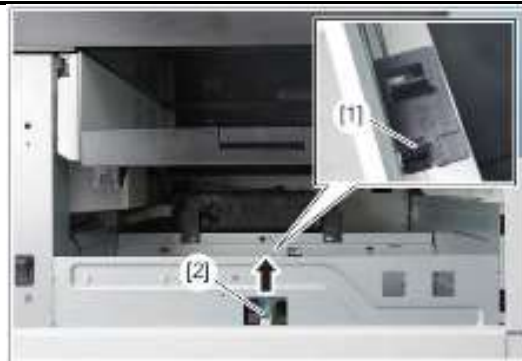

- 2、按下搭扣[1],连同支架一起拆下温度/湿度传感器[2]

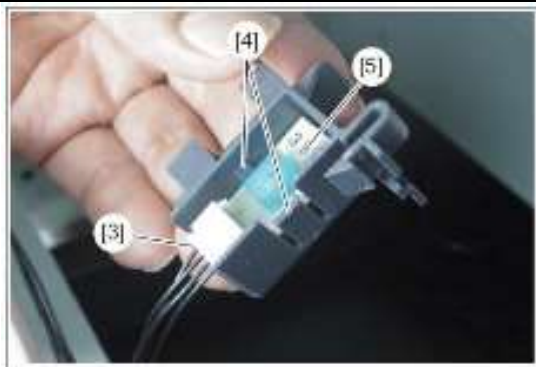

- 3、断开一处线束[3], 释放两侧卡扣[4], 拆下温度/湿度传感器 [5]

## 7.16 显影单元

- 1、拆下处理单元  
参考“7.1 处理单元”

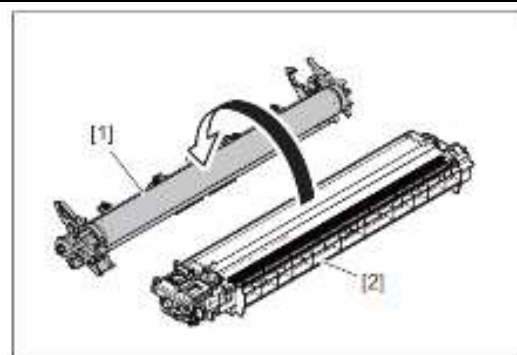

- 2、拆下鼓清洁单元  
参考“7.2 鼓清洁单元”

## 7.17 倒载体

- 1、拆下显影单元  
参考“7.16 显影单元”

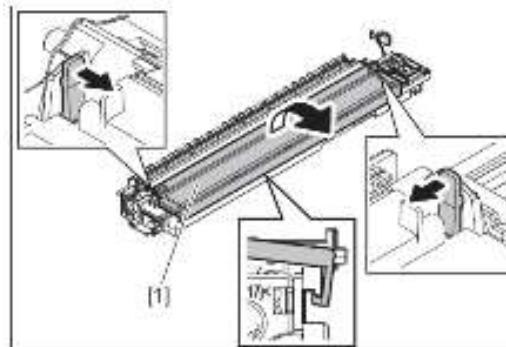

- 2、释放两侧卡扣, 翻转拆下显影单元上盖板[1]



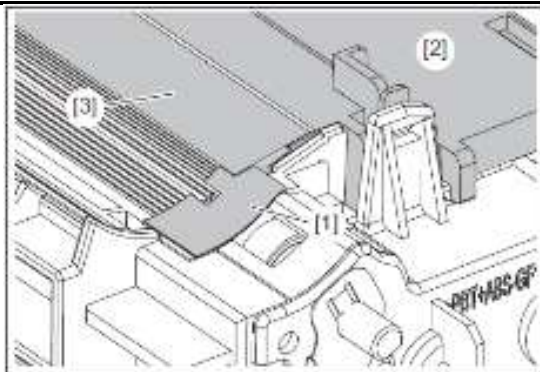

注意：安装上盖板时，确保侧密封片[1]位于上盖板与上密封片[3]之间

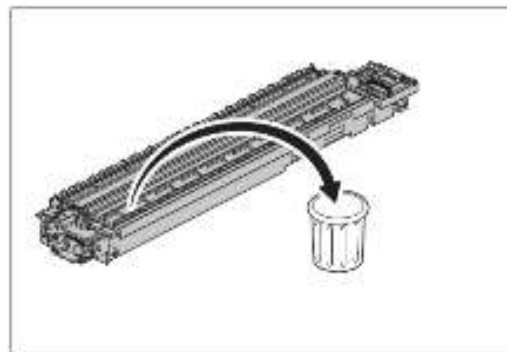

3、从后侧将载体从显影仓中导出

注意：倒载体时，避免载体掉落在显影单元驱动齿轮上

## 7.18 装载体

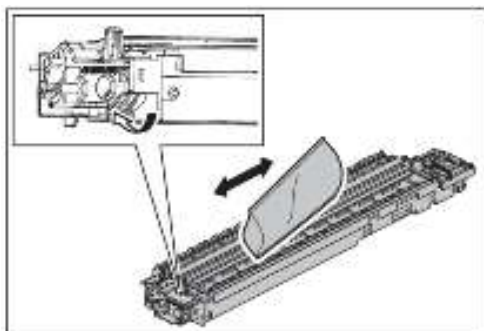

1、撕开载体包装袋，往显影仓中倒载体，过程中要旋转搅拌杆以确保载体在显影仓中分布均匀

## 7.19 自动墨粉浓度传感器 (S4)

1、倒载体

参考“7.17 倒载体”

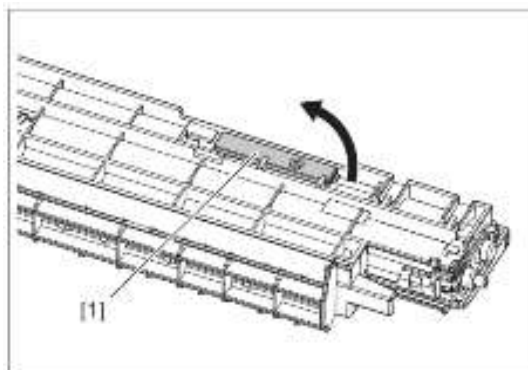

2、将显影仓翻转，释放线束，拆下自动墨粉浓度传感器[1]

## 7.20 磁穗刮刀

1、倒载体

参考“7.17 倒载体”

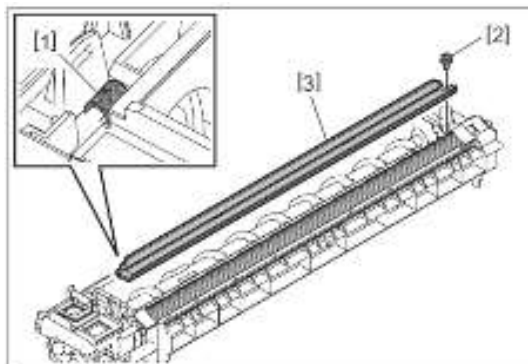

2、拆下弹簧[1]，拧下一颗螺丝[2]，拆下磁穗刮刀[3]

## 7.21 显影仓搅拌杆

### 1、倒载体

参考“7.17 倒载体”

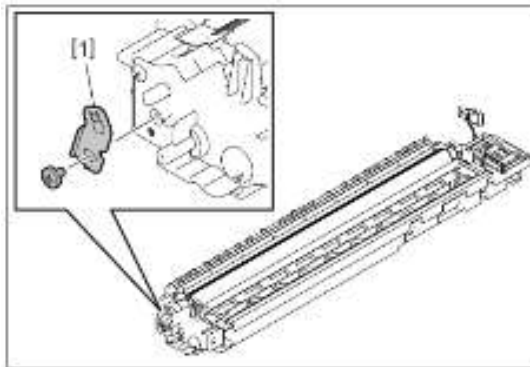

2、拧下一颗螺丝，拆下磁体方向调整拨片[1]

注意：拆装前，记录磁极方向调整拨片位置以确保恢复正确

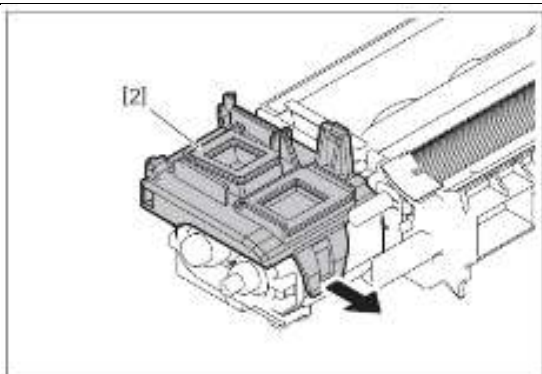

3、释放一处卡扣，取下回收粉下粉口盖板单元[2]

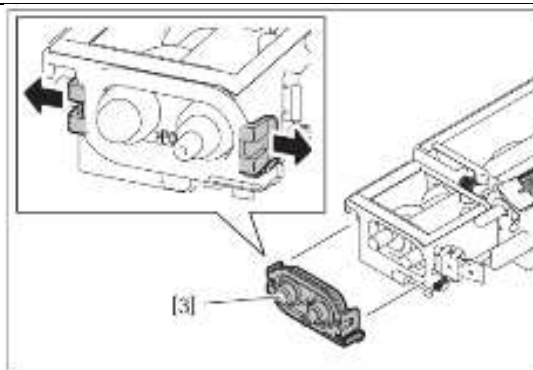

4、释放两侧卡扣，取下支架[3]

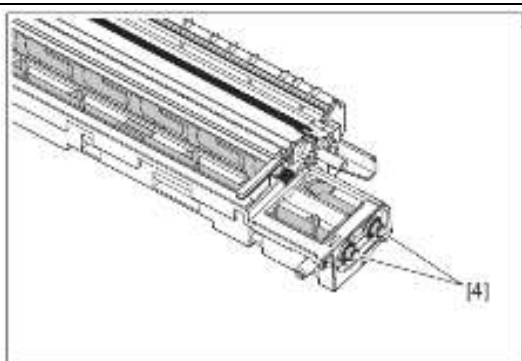

5、拆下两个显影仓搅拌杆[4]

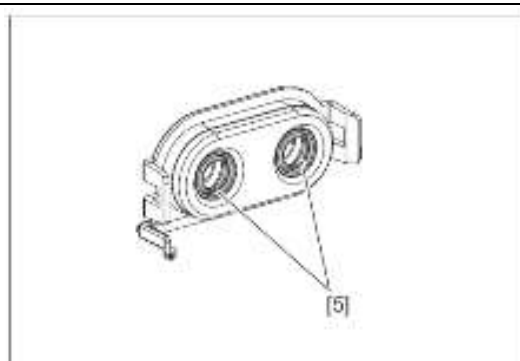

6、从支架上拆下两个油封[5]

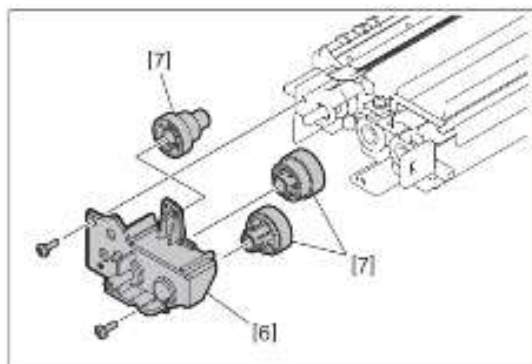

7、拧下两颗螺丝，拆下齿轮盒[6]后，取下三个齿轮[7]

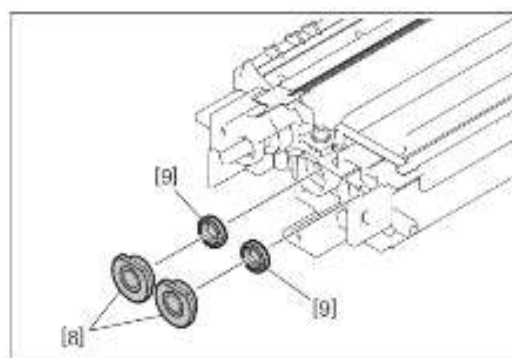

8、拆下两个轴套[8]和两个油封[9]

## 7.22 更换油封

1、使用小号螺丝刀插入油封的凹陷处，将其取出

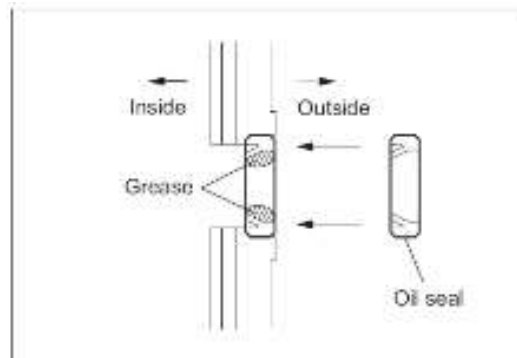

- 2、将新的油封水平推入支架或轴套中
- 3、对油封表面添加润滑油，并擦干净溢出部分

## 7.23 显影磁辊

1、倒载体  
参考“7.17 倒载体”

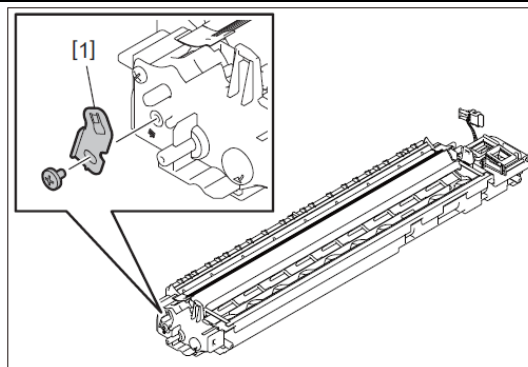

- 2、拧下一颗螺丝，拆下磁极方向调整拨片[1]
- 注意：拆装前，记录磁极方向调整拨片位置以确保恢复正确

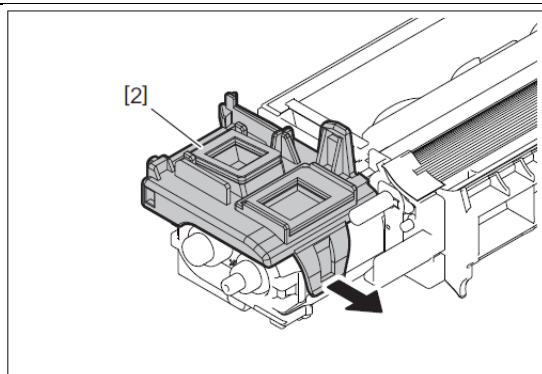

3、释放一处卡扣，取下回收粉下粉口盖板单元[2]

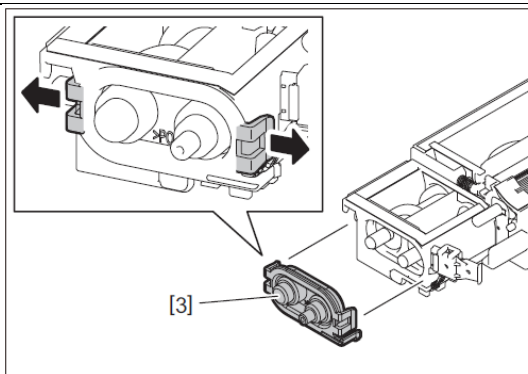

4、释放两侧卡扣，取下支架[3]

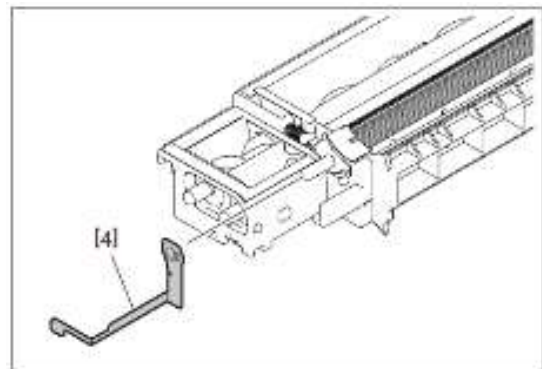

5、拆下叶片弹簧[4]

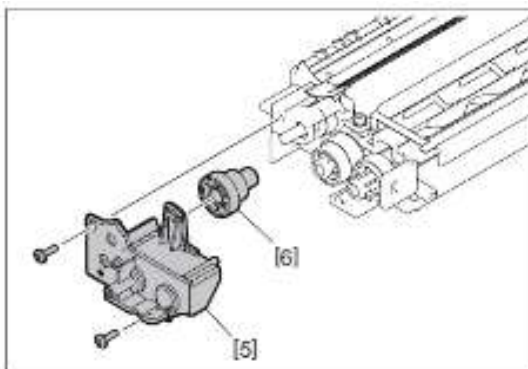

6、拧下两颗螺丝，拆下齿轮盒[5]，取下一个齿轮[6]

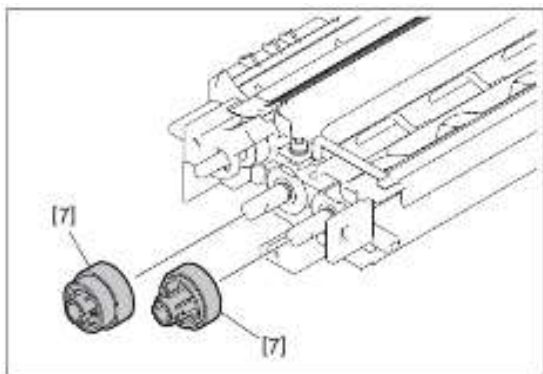

7、拆下两颗齿轮[7]

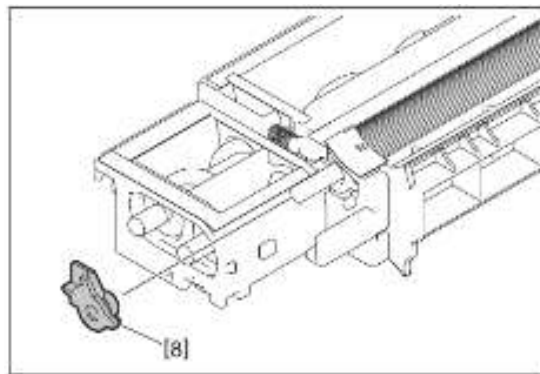

8、拆下前侧的一个轴套[8]

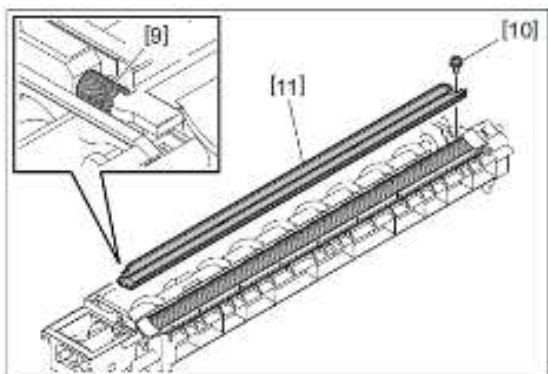

9、拆下一个弹簧[9]，拧下一颗螺丝[10]，拆下磁穗刮刀[11]

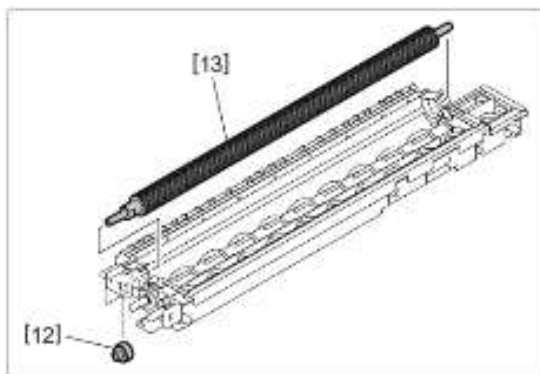

10、取下后侧齿轮[12]，拆下显影磁辊[13]

## 7.24 墨粉盒接口电路板 (CTIF)

1、拆下加粉电机

参考“5.2 加粉电机”

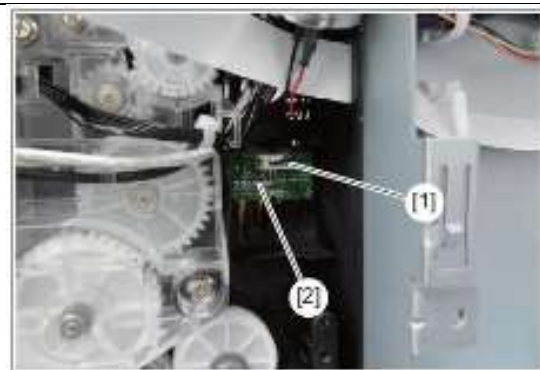

2、断开一处线束[1]，释放卡扣，拆下墨粉盒接口电路板[2]

注意：安装时避免接触弹簧变形

## 7.25 显影仓检测开关 (SW5)

1、拆下 ADU 风扇单元

参考“9.6 ADU 风扇单元”

2、拆下加粉电机

参考“5.2 加粉电机”

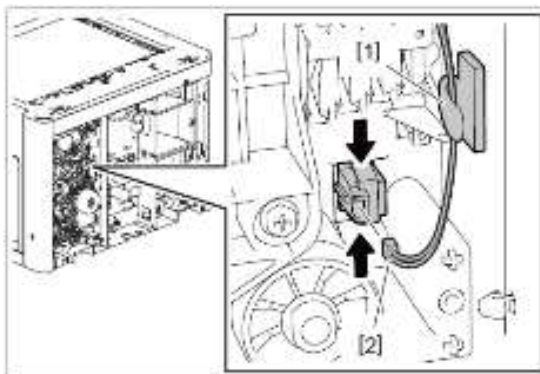

3、从线束夹[1]中释放线束，断开一处线束[2]，释放两侧卡扣



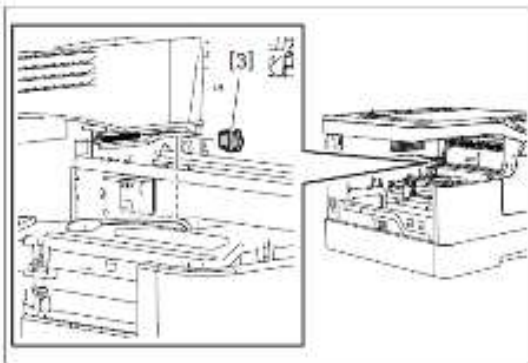

4、拆下显影仓检测开关[3]

## 八、定影/出口单元

注意：

拆装定影单元时，确保设备关机并断开电源线

拆装定影单元前，确保定影单元已经冷却至常温

拆装定影单元后，确保线束恢复至对应的线束夹或卡槽中

### 8.1 定影单元

1、拆下右后盖板

参考“1.9 右后盖板”

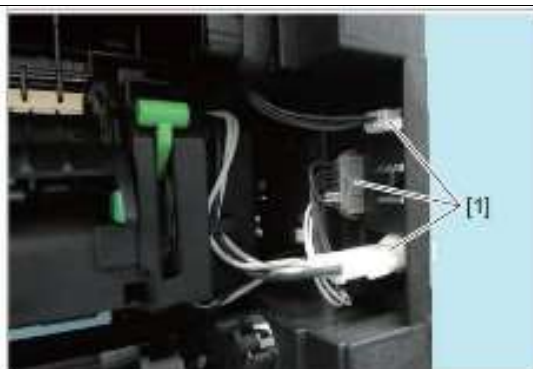

2、断开三处线束[1]，从线束导轨中释放线束

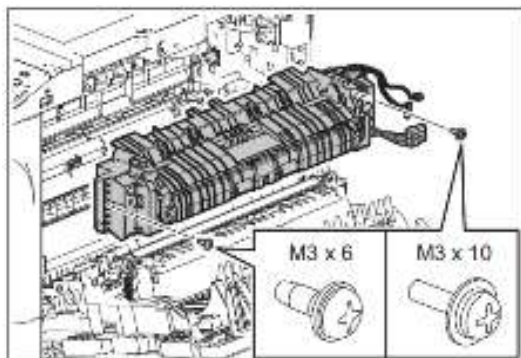

3、拧下两侧各一颗螺丝

注意：前侧 M3X6 阶梯螺丝，后侧 M3X10 普通螺丝



4、如图握持，拆下定影单元[2]

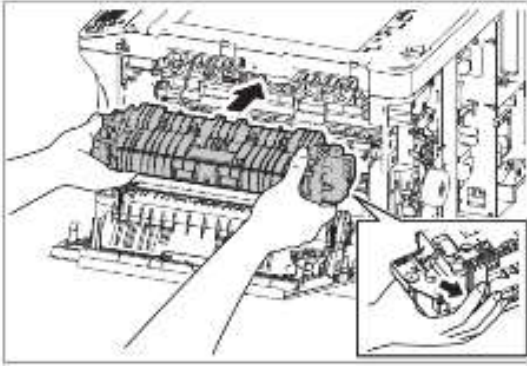

注意：安装定影单元时，握持图中所示位置

## 8.2 出口传感器 (S3)

1、拆下定影单元

参考“8.1 定影单元”



2、打开定影单元出口导板[1]

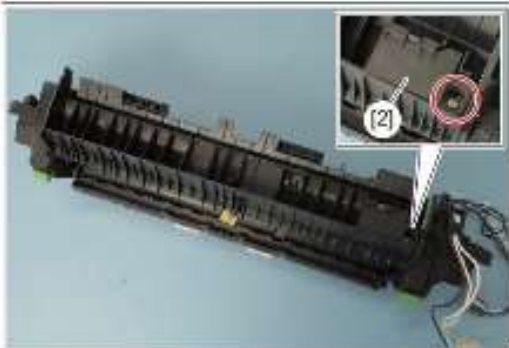

3、拧下一颗螺丝，拆下传感器盖板[2]

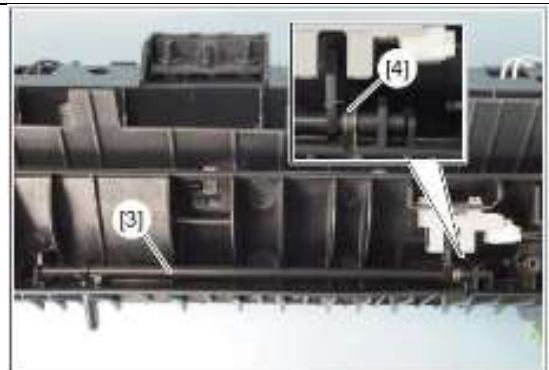

4、取下传感器臂杆[3]和弹簧[4]



注意：恢复安装臂杆时，如图所示安装弹簧

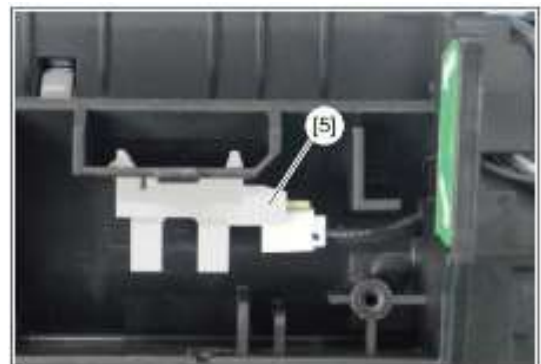

5、释放三处卡扣，拆下出口传感器[5]并断开线束

## 8.3 定影单元上盖板/出口导板

### 1、拆下定影单元

参考“8.1 定影单元”



2、翻转定影单元朝下，拧下一颗螺丝，释放卡扣，取下接地簧片

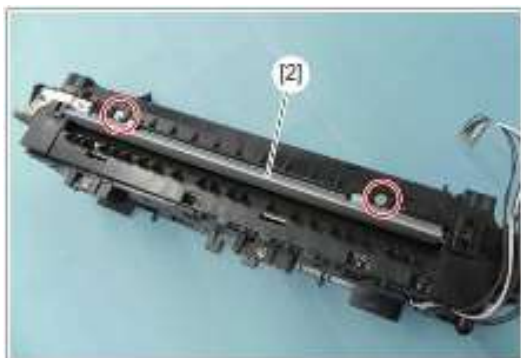

### 3、拧下两颗螺丝，拆下入口导板[2]

注意：拆装时防止导板刮伤热辊和压力辊



注意：安装入口导板时，确保图中卡销位于定影外侧，并注意螺丝孔位置是否正确

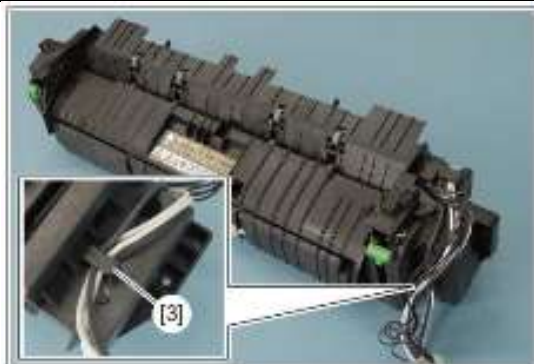

### 4、从卡扣[3]中释放线束



### 5、从卡扣[3]中释放线束

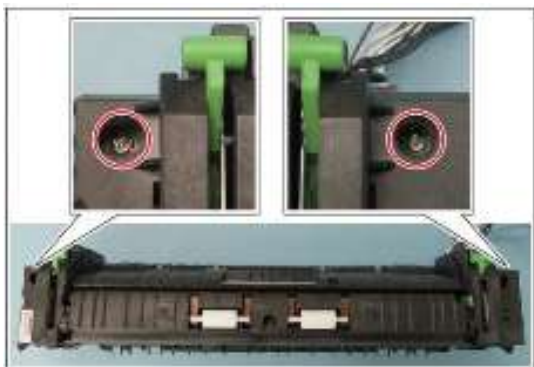

### 6、拧下定影单元两侧各一颗螺丝

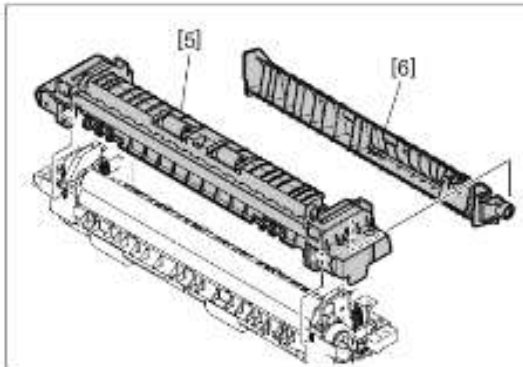

### 7、释放两个卡扣，取下定影单元上盖板[5]和定影出口导板[6]



## 8.4 中央加热灯 ( LAMP1 )

- 1、拆下定影单元上盖板/出口导板  
参考 “8.3 定影单元上盖板/出口导板”

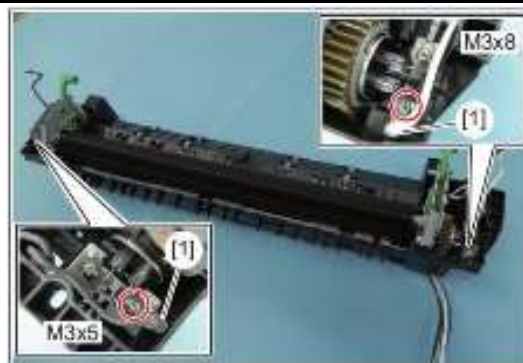

- 2、从两侧端子[1]上拔下线束

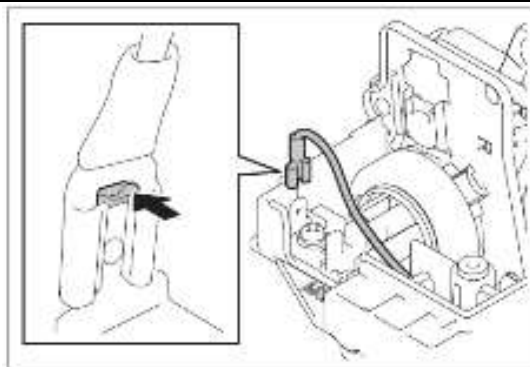

注意：插拔端子时注意先按下锁扣，避免使用蛮力以防止损坏

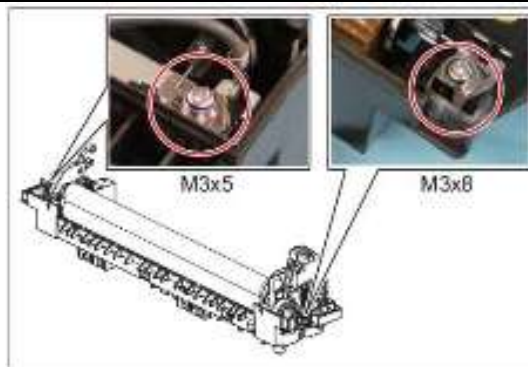

- 3、拧下两颗螺丝：前侧为 M3X5，后侧为 M3X8

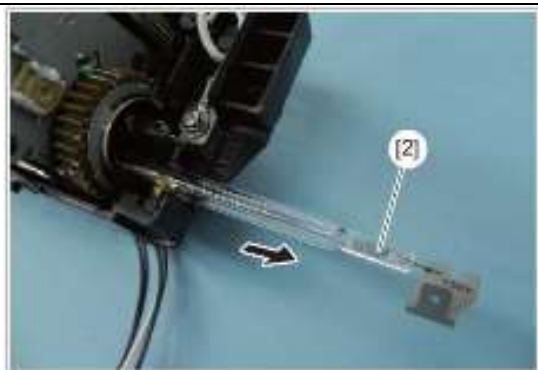

- 4、从后侧取下中央加热灯[2]  
注意：抽出加热灯时，避免触碰灯管本体部分

## 8.5 侧加热灯 ( LAMP2 )

- 1、拆下定影单元上盖板/出口导板  
参考 “8.3 定影单元上盖板/出口导板”

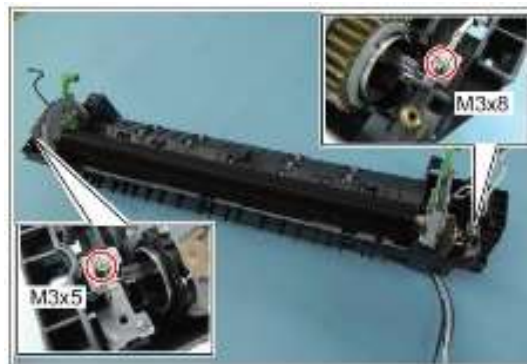

- 2、拧下两颗螺丝：前侧为 M3X5，后侧为 M3X8



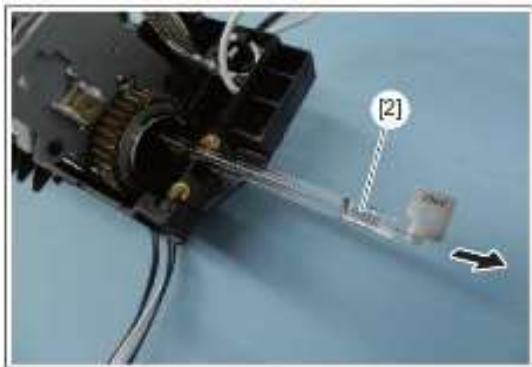

3、从后侧取下侧加热灯[2]

注意：抽出加热灯时，避免触碰灯管本体部分

## 8.6 基座单元

1、拆下中央加热灯

参考“8.4 中央加热灯”

2、拆下侧加热灯

参考“8.5 侧加热灯”

3、拆下中央热敏电阻、侧热敏电阻和边缘热敏电阻

参考“8.11 中央热敏电阻、侧热敏电阻和边缘热敏电阻”

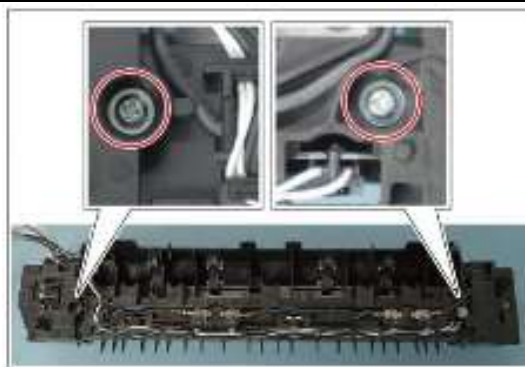

4、将定影单元翻转放置，拧下两颗螺丝

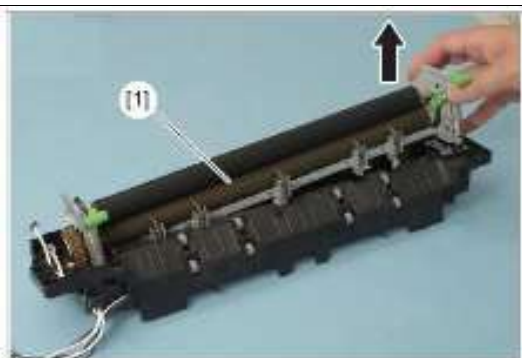

5、将定影单元正面放置，从上部取下基座单元[1]

## 8.7 压力辊

1、拆下基座单元

参考“8.6 基座单元”



2、拆下前后侧两个压力弹簧[1]，拆下两个压力释放杆[2]

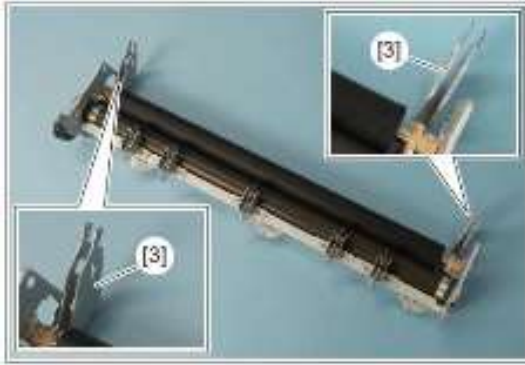

3、拆下两个压力释放杆臂杆[3]

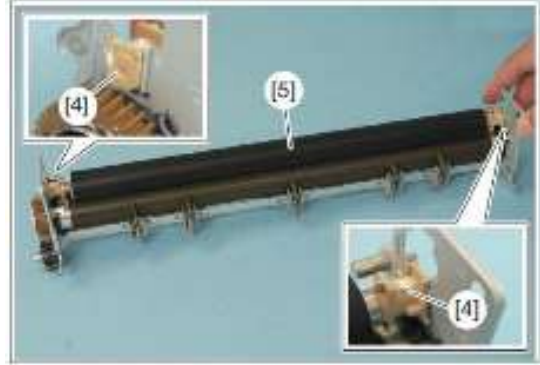

4、释放两侧轴套[4]，取下压力辊[5]

## 8.8 分离爪

1、拆下基座单元

参考“8.6 基座单元”

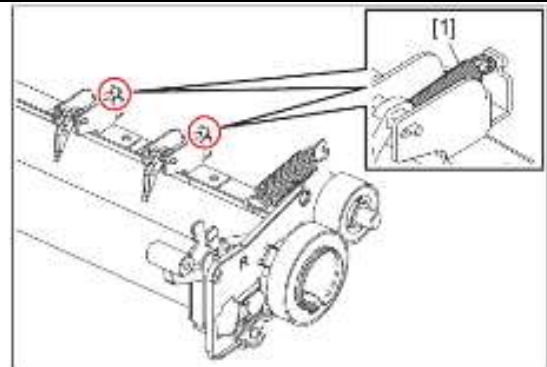

2、拆下各个分离爪上的弹簧[1]

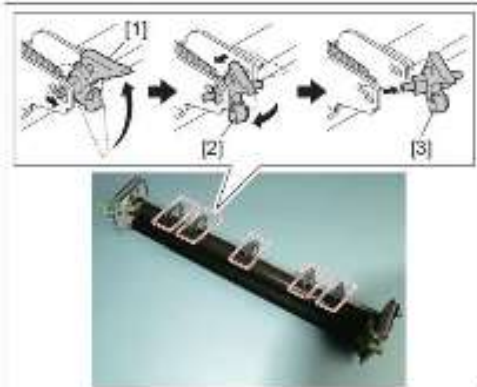

3、按图中步骤拆下分离爪

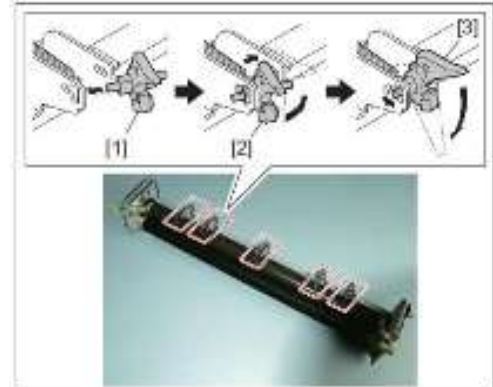

注意：安装分离爪时，按图中顺序完成

## 8.9 热辊/热辊轴套

1、拆下压力辊

参考“8.7 压力辊”

2、拆下分离爪

参考“8.8 分离爪”

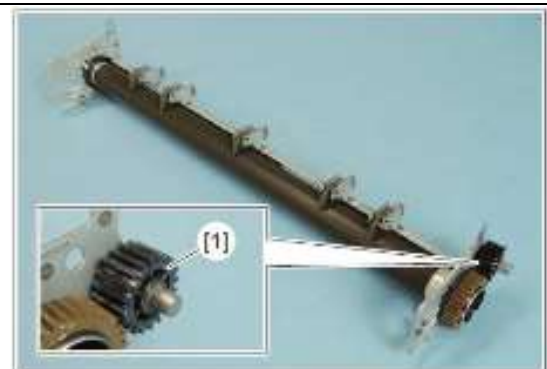

3、取下一个齿轮[1]



4、取下前后侧各一个 C 型环[2]，取下一个齿轮[3]



5、拆下两侧热辊轴套[4]



6、拆下热棍[5]

## 8.10 中央热保险 ( THMO1 ) /侧热保险 ( THMO2 )

1、拆下定影单元

参考“8.1 定影单元”

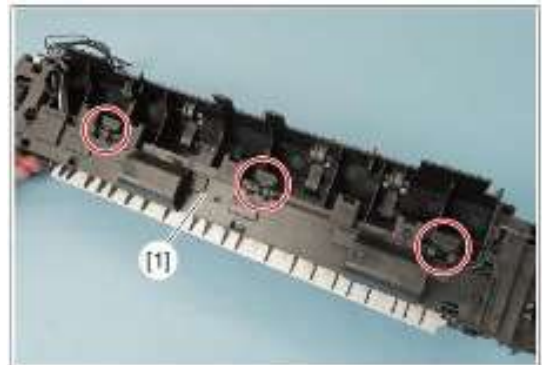

2、释放三处卡扣，取下线束导板[1]

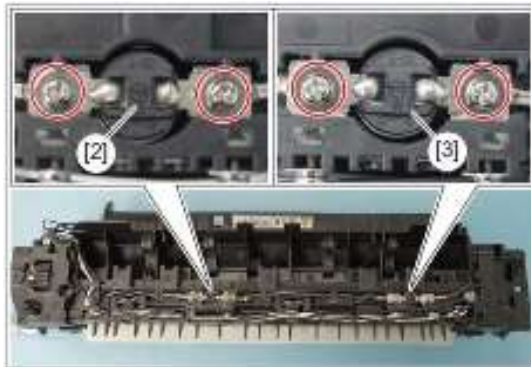

3、拧下两颗螺丝，取下中央热保险 ( THMO1 ) [2]  
拧下两颗螺丝，取下侧热保险 ( THMO2 ) [3]

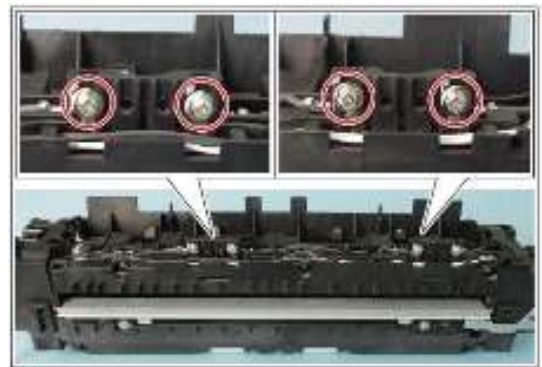

注意：不要拆装图中四颗螺丝



## 8.11 中央热敏电阻( THMS1 )/侧热敏电阻( THMS2 ) /边缘热敏电阻 ( THMS3 )

1、拆下定影单元

参考“8.1 定影单元”

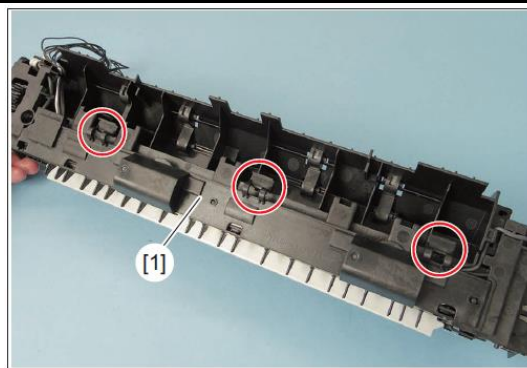

2、释放三处卡扣，取下线束导板[1]

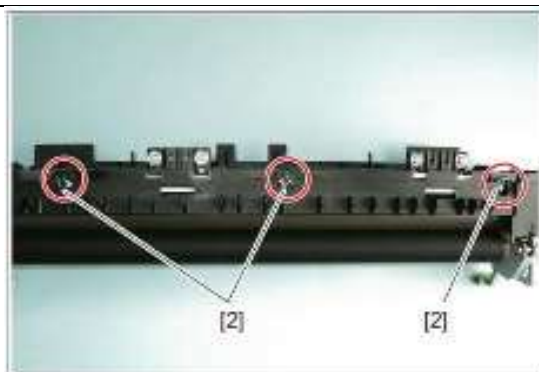

3、拧下每个热敏电阻的一颗螺丝，从线束槽中释放线束后取下热敏电阻[2]

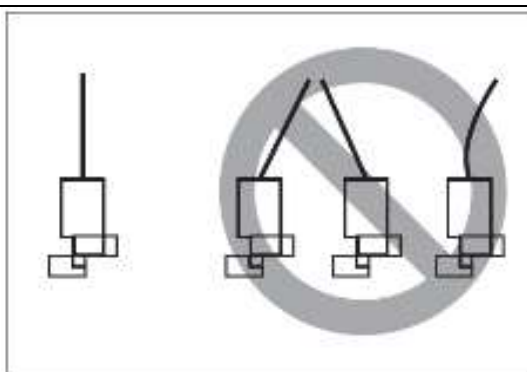

注意：安装热敏电阻时，检查热敏电阻贴片是否变形

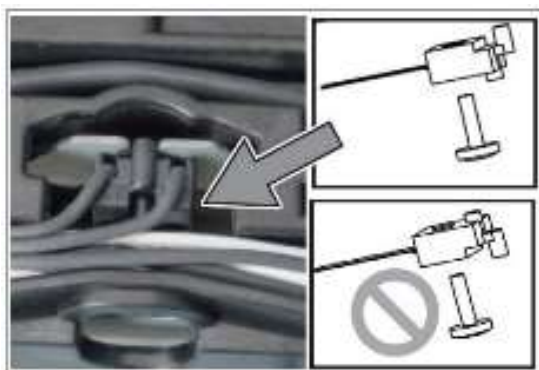

注意：安装时确保热敏电阻的朝向正确

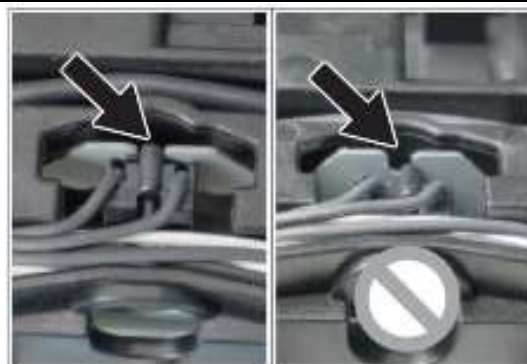

注意：检查确认是否安装到位，热敏电阻与热棍的间隙是否正常

## 8.12 出口辊

1、拆下托盘后盖板

参考“1.7 托盘后盖板”

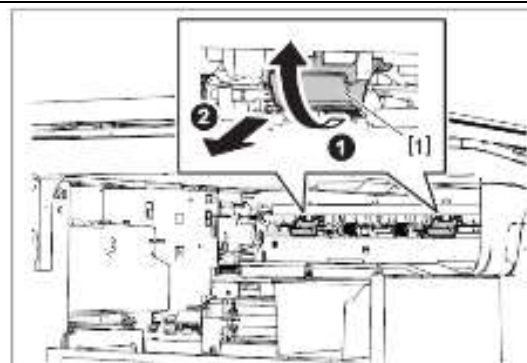

2、拆下两个出口防折角拨杆[1]



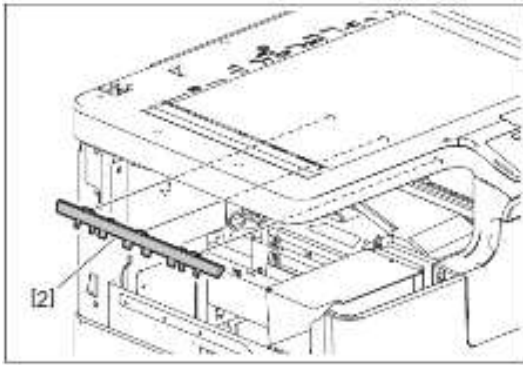

3、如果安装了出口导板[2]，将其拆下

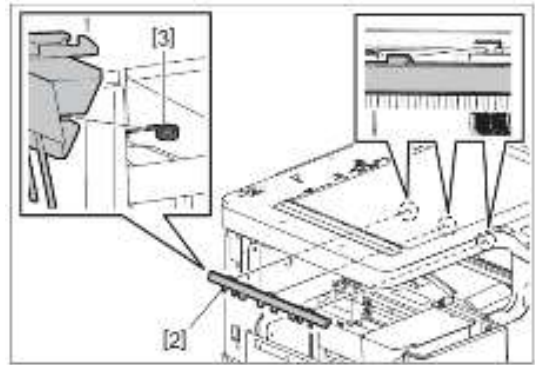

注意：安装出口导板[2]后，将接地弹簧[3]插入对应的沟槽内

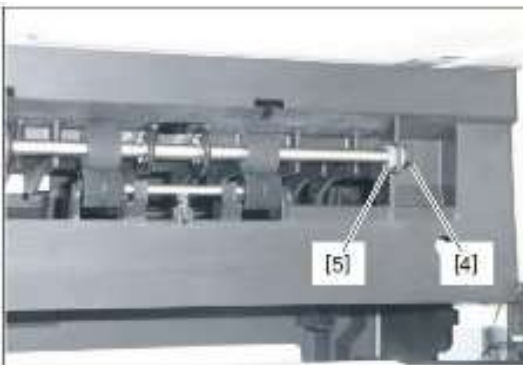

4、拆下一个卡扣[4]，取下轴套[5]

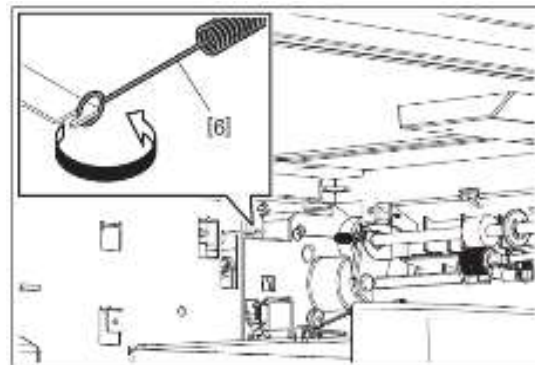

5、取下接地弹簧[6]

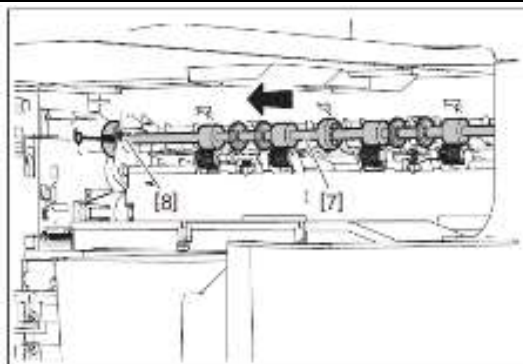

6、将出口辊[7]向后侧移动，将轴套[8]从支架上取下

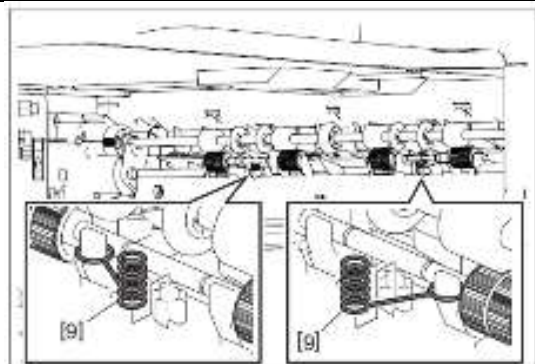

7、拆下两个弹簧[9]

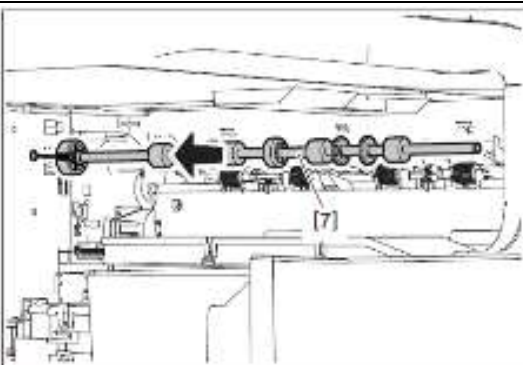

8、沿箭头方向取下出口辊[7]

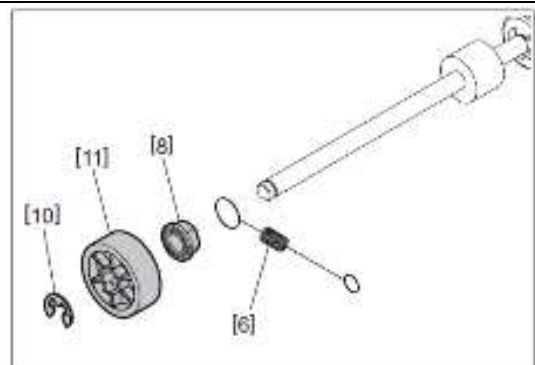

9、取下一个 E 型环[10]、一个齿轮[11]、一个接地弹簧[6]和一个轴套[8]

## 九、自动双面单元 (ADU)

### 9.1 自动双面单元 (ADU)

- 1、关闭复合机并断开电源线
  - 2、打开侧盖板
  - 3、拆下转分座
- 参考“6.3 转分座”



- 4、断开 ADU 的一个线束[1]

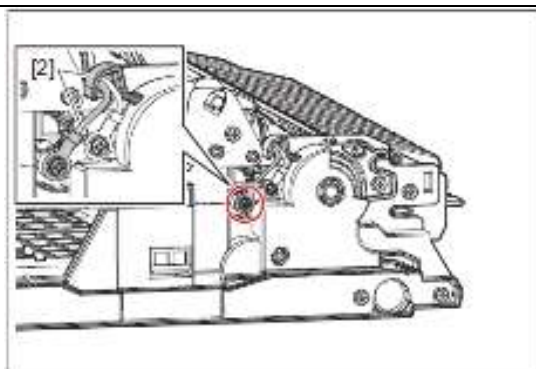

- 5、拧下一颗螺丝

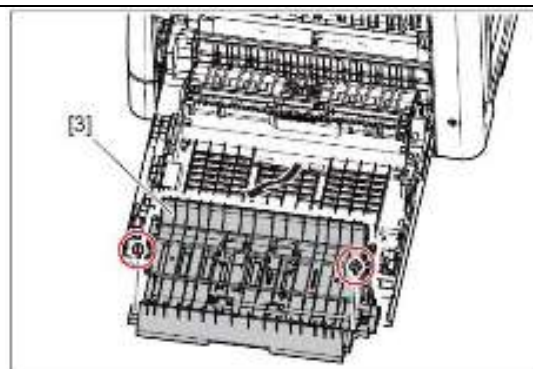

- 6、拧下两颗螺丝，拆下 ADU 单元[3]

### 9.2 ADU 传感器 (S8)

- 1、拆下 ADU
- 参考“9.1 ADU”



- 2、断开一处线束，释放三个卡扣，拆下 ADU 传感器[1]

### 9.3 定影导板单元

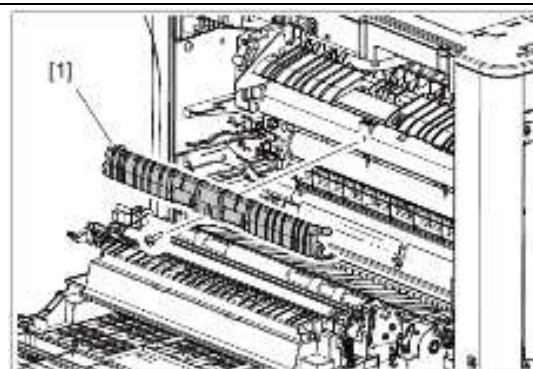

- 1、拧下一颗螺丝，从定影单元上拆下定影导板单元[1]

## 9.4 出口电机 ( M6 )

- 1、拆下后盖板  
参考 “1.8 后盖板”

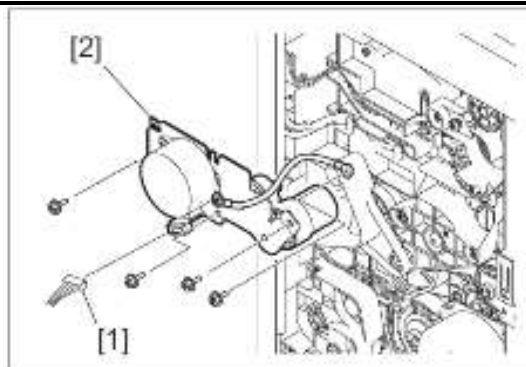

- 2、断开一处线束[1]，拧下四颗螺丝，取下整个出口电机支架[2]

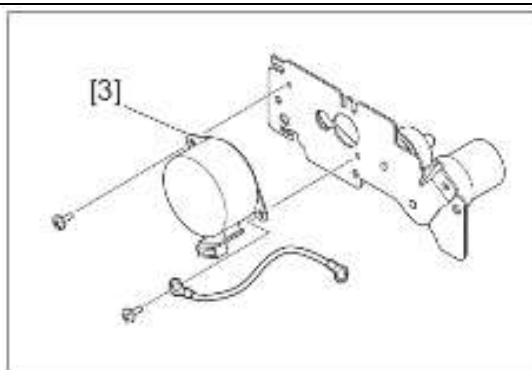

- 3、拧下两颗螺丝，拆下出口电机 ( M6 ) [3]

## 9.5 ADU 离合器 ( CLT4 )

注意：安装离合器时，注意离合器限位卡口位置

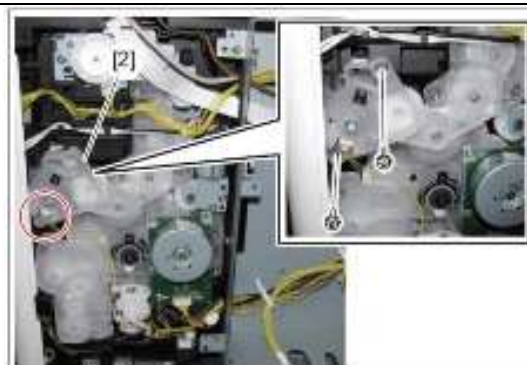

- 1、断开一处线束[1]，拧下两颗螺丝，拆下 ADU 离合器[2]

## 9.6 ADU 风扇风道单元

- 1、拆下内部托盘  
参考 “1.2 内部托盘”

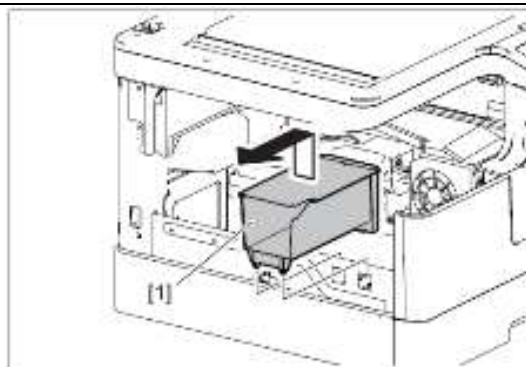

- 2、拆下 ADU 风扇风道[1]



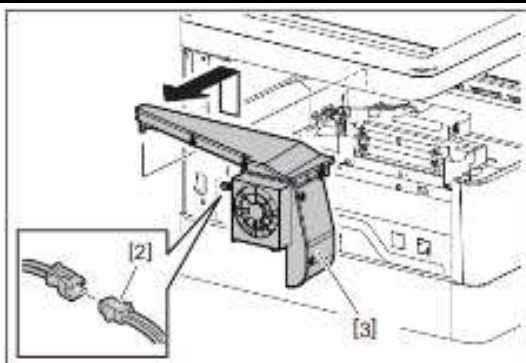

3、断开风扇线束[2]，拆下 ADU 风扇风道单元[3]

## 9.7 ADU 下输纸辊

1、拆下 ADU  
参考“9.1 ADU”



2、拆下两个 E 型环[2]、一个滑轮[2]和一个定位销[3]



3、取下两侧轴套[5]，拆下 ADU 下输纸辊[6]

## 9.8 ADU 上输纸辊

1、拆下 ADU 单元  
参考“9.1 ADU 单元”  
2、拆下 ADU 下输纸辊  
参考“9.7 ADU 下输纸辊”

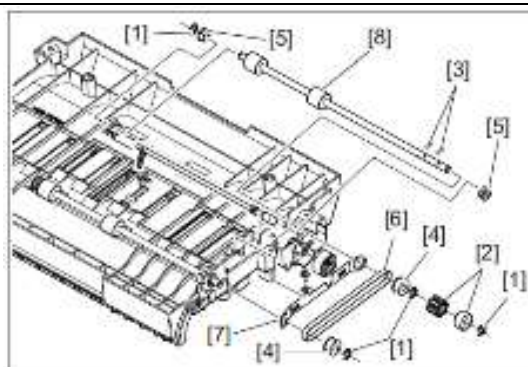

2、拆下四个 E 型环[1]、两个齿轮[2]、两个定位销[3]、两个滑轮[4]、两个轴套[5]、一条皮带[6]和接地片[7]，拆下上输纸辊[8]



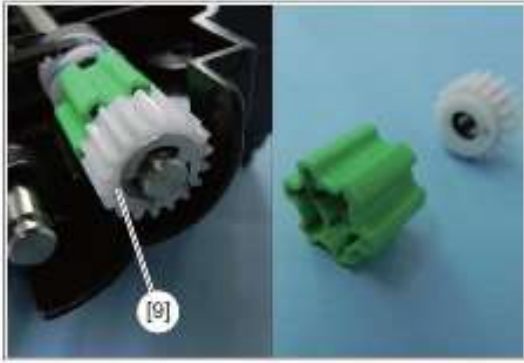

注意：安装时需要注意齿轮朝向[9]

## 9.9 ADU 输纸辊

- 1、拆下 ADU 单元  
参考“9.1 ADU 单元”

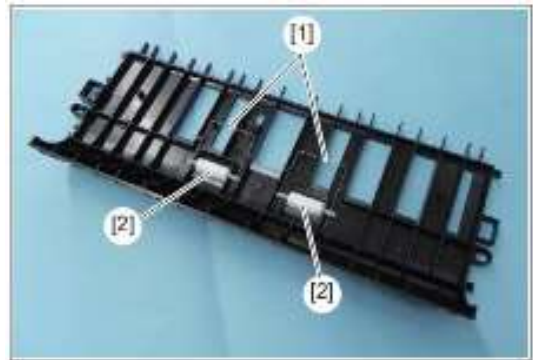

- 2、拆下两个弹簧[1]，取下两个 ADU 输纸辊[2]

## 十、选购件安装和更换

### 10.1 自动双面输稿器 (RADF)

- 1、关闭复合机并断开电源线



- 2、拧下一颗螺丝，拆下接口盖板[1]

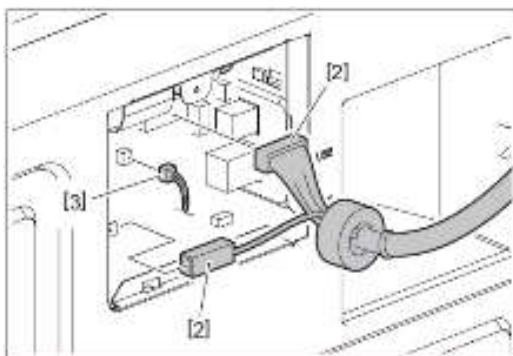

- 3、断开两个线束[2] (无线束[3])

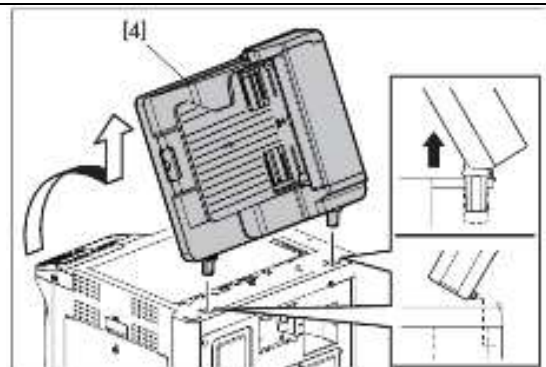

- 4、将输稿器[4]从铰链中取出

## 10.2 纸盒单元 (PFU)

- 1、关闭复合机并断开电源线
  - 2、取下第一纸盒
  - 3、拆下后盖板
- 参考“1.8 后盖板”

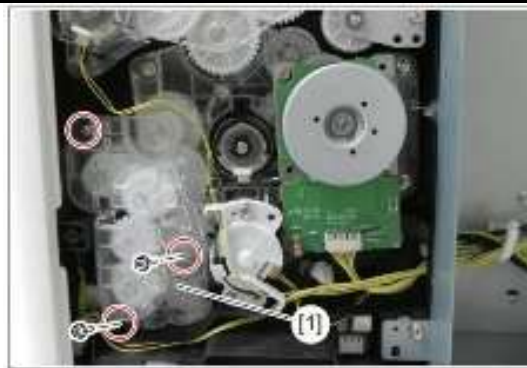

- 4、拧下三颗螺丝，拆下 PFU 齿轮单元[11]

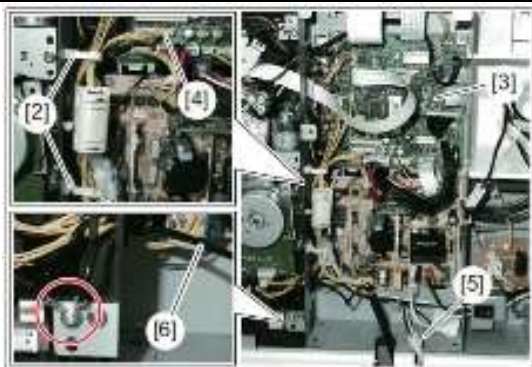

- 5、释放两个卡扣[2]，从主板[3]上断开一处线束[4]
- 6、断开一处线束[5]，拧下一颗螺丝，拆下接地线[6]



- 7、取下第一、第二纸盒
- 8、拧下一颗螺丝，取下左前侧固定支架片[7]

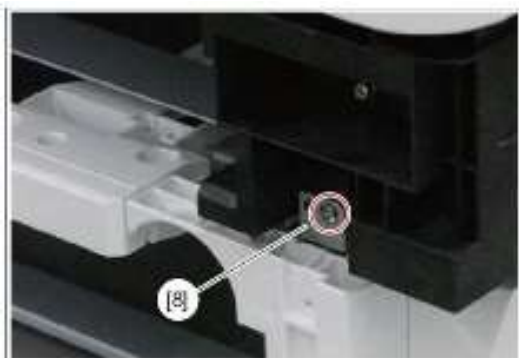

- 9、拧下一颗螺丝，拆下右前侧固定支架片[8]



- 10、拧下一颗螺丝，拆下左后侧固定支架片[9]



- 11、拧下一颗螺丝，拆下右后侧固定支架片[10]

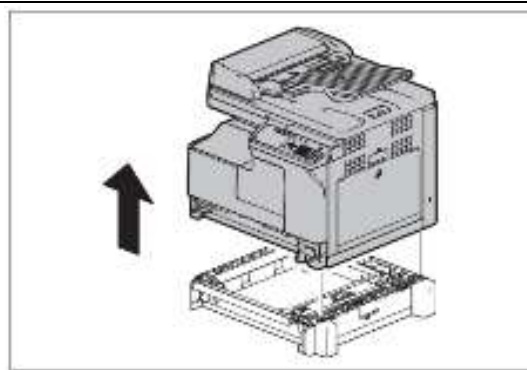

- 12、将复合机与 PFU 分离并取下

## 十一、电路板相关

### 11.1 主板

- 1、拆下后盖板  
参考“1.8 后盖板”

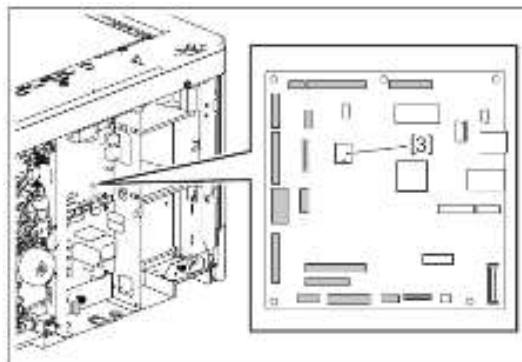

- 2、断开主板上的所有线束

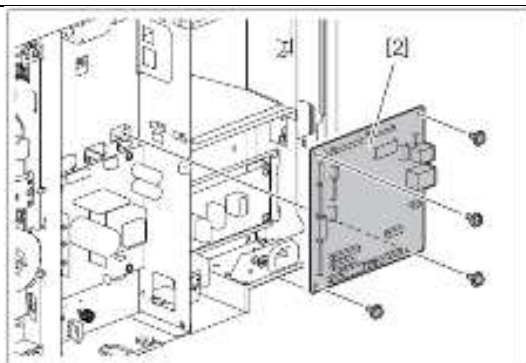

- 3、拧下四颗螺丝，取下主板  
注意：更换主板的相关其他操作步骤请参阅便携手册对应内容

### 11.2 低压电源板 (LVPS)

- 1、拆下后盖板  
参考“1.8 后盖板”



- 2、断开低压电源板上的所有线束



- 3、拧松四颗螺丝，拆下低压电源板[1]

## 11.3 高压板 (HVPS)

1、拆下右前盖板

参考“1.3 右前盖板”

2、拆下左前盖板

参考“1.4 左前盖板”

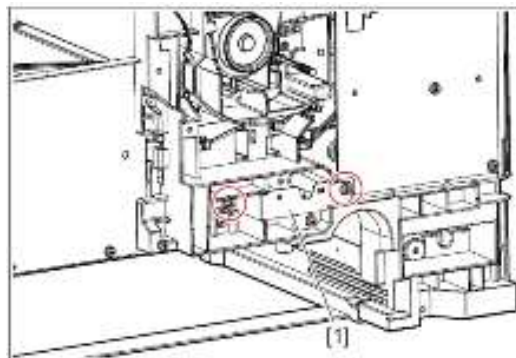

3、拧下两颗螺丝，拆下支架[1]

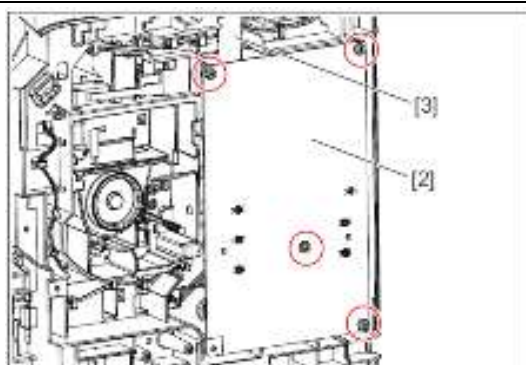

4、拧下四颗螺丝，拆下高压板[2]，之后断开扁平线束[3]

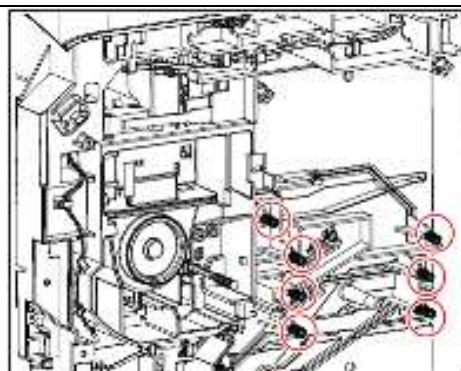

注意：安装高压板时避免七个高压接触弹簧变形